

dev.a

User Manual

Firmware v1.2.0.75



Contacts

Get in touch with us if you need support or information about our products:

- Website: <https://analogico.adel2000.it>
- Email: support@analogico.adel2000.it
- Phone: +39 059 2550137
- Address: Via Emilia Est 1401/2, Modena, 41122, Italy

Copyright all rights reserved © 2000 - 2022, Adel Srl

Contents

I	Part One: Introduction	
1	The Machine	11
1.1	Features	11
1.1.1	Containers lids	16
1.1.2	Disclaimer	16
2	The tanks	17
2.1	Magnetic rotation tanks	17
2.2	Mechanical rotation tanks	19
2.3	Film capacity	20
2.4	Required chemistry	20
2.5	Loading the tanks	21
2.5.1	Film retaining clips	22
3	Technical specifications	27
3.1	Size, weight and voltage	27
3.2	Electrical requirements	27
3.2.1	Power backup	28
3.3	Hydraulic requirements	28
3.4	Installation	29

II

Part Two: Operations

4	Using dev.a	33
4.1	Turning on the machine	33
4.2	Turning off the machine	33
4.3	Processes and steps	33
4.3.1	Processes	33
4.3.2	Steps	34
4.3.3	Example	35
4.3.4	Notes about film processing	36
4.4	Execution of a process	37
4.5	Temperature control	38
4.5.1	Low chemistry volumes and temperature control	40
4.5.2	Important notes about temperature control and water management	41
4.6	User interface	42
4.6.1	Main interface - Processes tab	42
4.6.2	Main interface - Configuration tab	43
4.6.3	Main interface - Tools tab	47
4.6.4	Process detail view	48
4.6.5	Process edit view	49
4.6.6	Process execution view	50
4.7	Executing a process	57

III

Part Three: Maintenance

5	Other features	61
5.1	Internal washes	61
5.2	No-lights mode	61
6	Maintenance and special processes	63
6.1	Special processes	63
6.2	Cleaning the machine and the “Cleaning process”	63
6.2.1	Removing limescale deposits	65
6.2.2	Cleaning filters	65
6.3	Draining the water bath	66
6.4	The “Self-check process”	66
6.4.1	Before starting	66
6.4.2	The self-check tasks	67
6.5	Tank presence and rotation sensors adjustment	70
7	Software and data	75
7.1	Software upgrades	75
7.2	User data import/export	76
7.2.1	Exporting data	76

7.2.2	Importing data	76
8	Troubleshooting	77
8.1	Common issues	77

Revision History

Version	Date	Description
1.1.3.40	28/05/2021	First release.
1.1.4.46	01/09/2021	Added the possibility to use lower amounts of chemistry in specific situations and added warnings about temperature control issues related to the use of low amounts of chemistry. Updated the temperature control process and made the tank size choice persistent across reboots. Added film rotation checking during processing, extended the multi-rinse cycle duration and fixed some software bugs.
1.1.4.49	17/09/2021	Added the customizable cleaning process, lowered the minimum process temperature from 20 °C to 18 °C and fixed some software issues.
1.1.4.53	05/10/2021	Fixed some software bugs.
1.1.4.54	13/10/2021	Improved hardware handling and fixed software bugs.
1.1.4.57	03/11/2021	Made the “water not recirculating” error skip-pable.

1.1.5.60	10/12/2021	Added new options in the configuration screen, added the “drain tank” option to the stop process dialog, replaced the tank lock check with a warning dialog, added the temperature tolerance to process parameters, added the degree symbol to the keyboard and added support for USB drive formatted using different file systems.
1.1.5.62	16/02/2022	Added the “Repeat” option to the cleaning process setup and updated the user manual “Cleaning and maintenance” chapter, adjusted pump times.
1.1.5.63	01/03/2022	Bug fixes.
1.2.0.67	07/07/2022	Added a more comprehensive self-check process, lowered the minimum rotation speed to 20 rpm, various bug fixes and improvements. Added details about the mechanical rotation system.
1.2.0.68	17/10/2022	Minor bug fixes.
1.2.0.72	03/04/2023	Added the possibility to reset the temperature sensors tuning values and added a new feature to slightly randomize the rotation inversion interval.
1.2.0.74	07/09/2023	Minor fixes and improvements.
1.2.0.75	06/09/2024	Minor fixes for hardware compatibility.



Part One: Introduction

1	The Machine	11
1.1	Features	
2	The tanks	17
2.1	Magnetic rotation tanks	
2.2	Mechanical rotation tanks	
2.3	Film capacity	
2.4	Required chemistry	
2.5	Loading the tanks	
3	Technical specifications	27
3.1	Size, weight and voltage	
3.2	Electrical requirements	
3.3	Hydraulic requirements	
3.4	Installation	

1. The Machine

1.1 Features

Dev.a is a fully automatic, fully customizable, rotary film development machine. Its main features are:

- Support for all commonly available film formats, from 35mm to 8x10.
- Support for all common photographic processes (Black and white, C41, E6, etc.)
- Processing temperature can be automatically controlled using a tempered water bath.
- Up to 6 different chemicals can be used in a process.
- Up to 100 custom processes can be stored on the machine.
- Each process can have up to 30 different steps.
- Repeatable and predictable results.
- All processes are user-defined, no built-in process is provided to allow the user to completely customize the machine's behavior
- The machine can be connected to a pressurized water source for automatic water management.
- A large 7" touch display is used to interact with the machine.
- Chemicals can be discarded or recovered after processing, depending on user needs.
- Automatic cleaning process.
- Processes and settings can be exported and imported using a USB drive.
- Compatible with Paterson, AP and Jobo 1500 series reels for 35mm and 120 film.
- Custom reels for large formats (4x5, 5x7 and 8x10).
- The display backlight and the power LED can be switched off if total darkness is required.

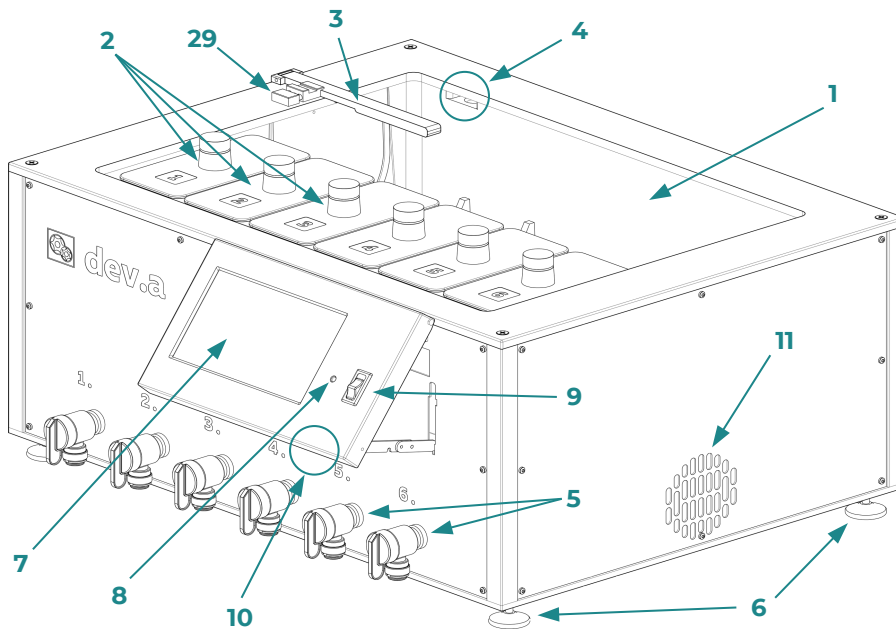

(a) Front of the machine

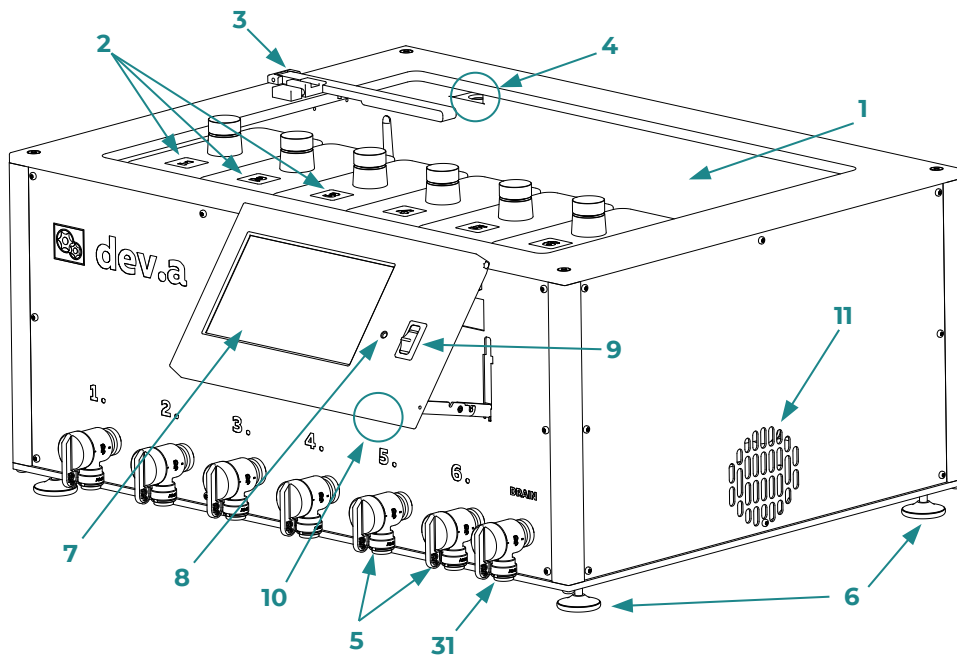

(b) Front of the machine in the mechanical rotation version

Figure 1.1: Front of the machine

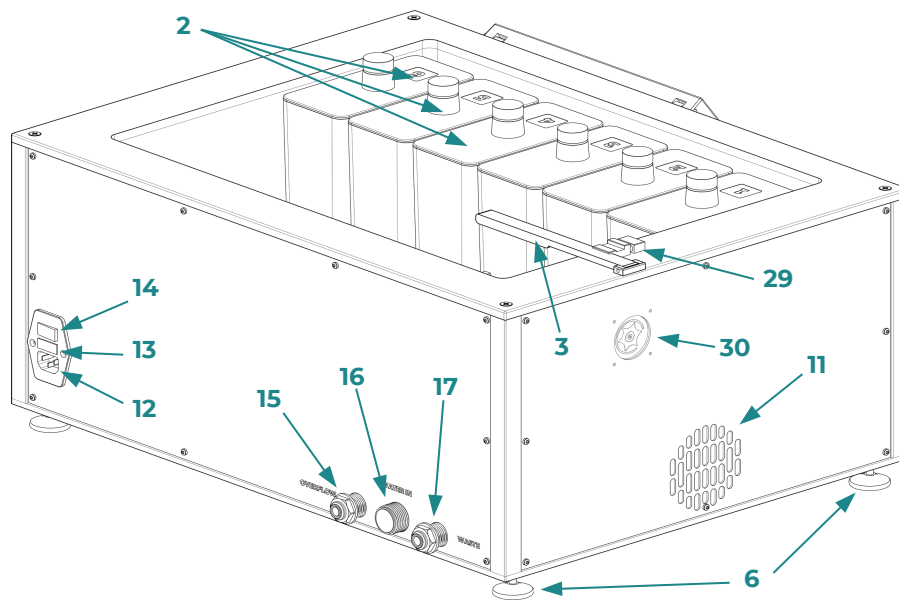

(a) Back of the machine

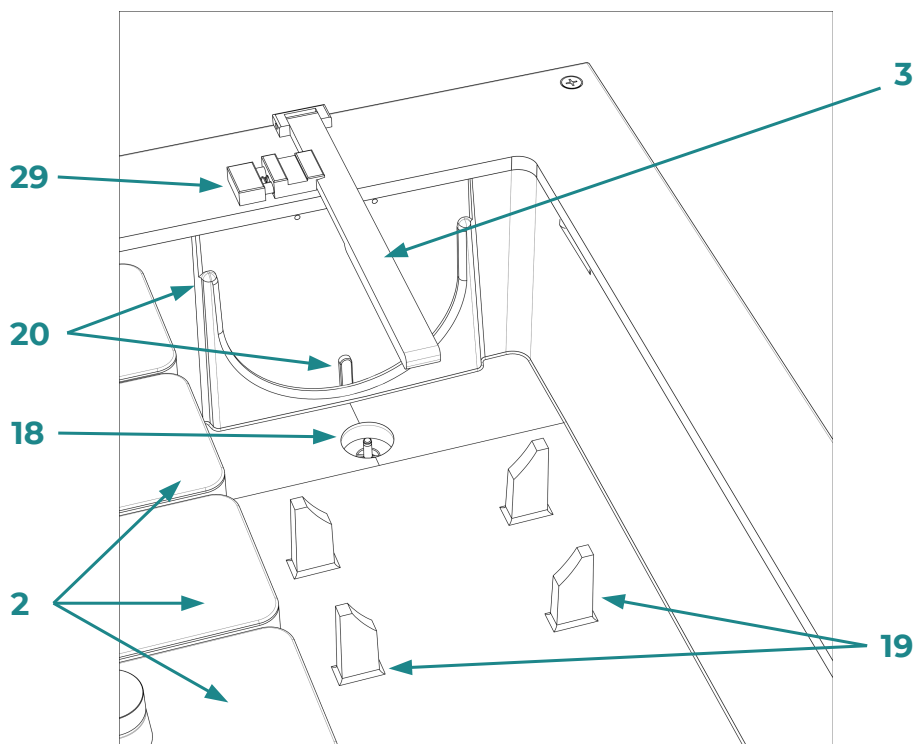

(b) Tank area in the magnetic rotation version

Figure 1.2: Back of the machine and details of the tank area

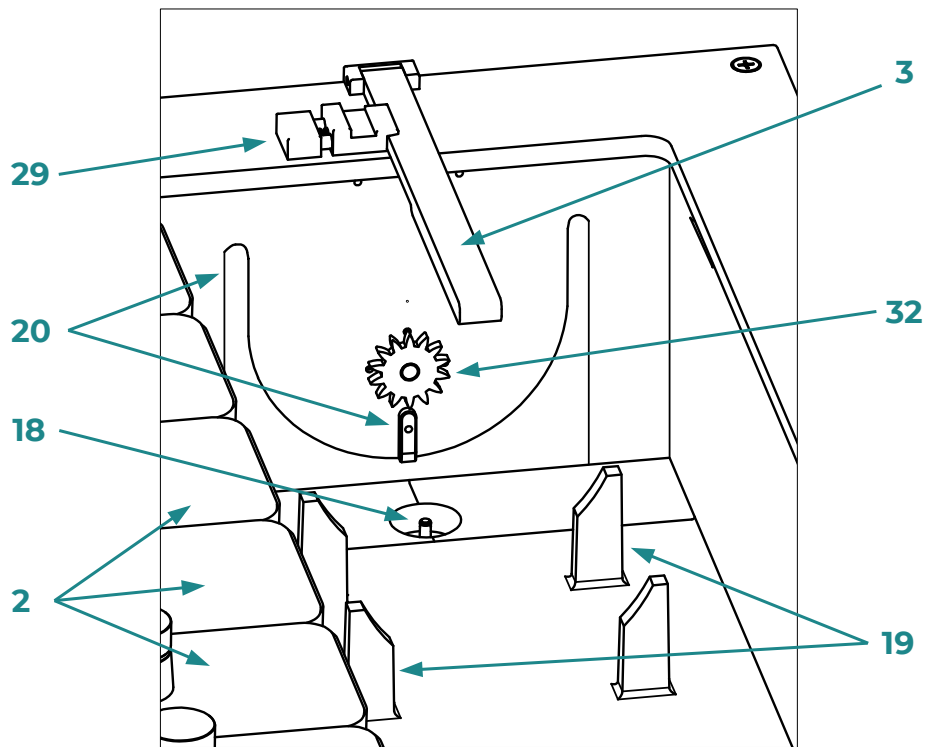

(a) Tank area in the mechanical rotation version

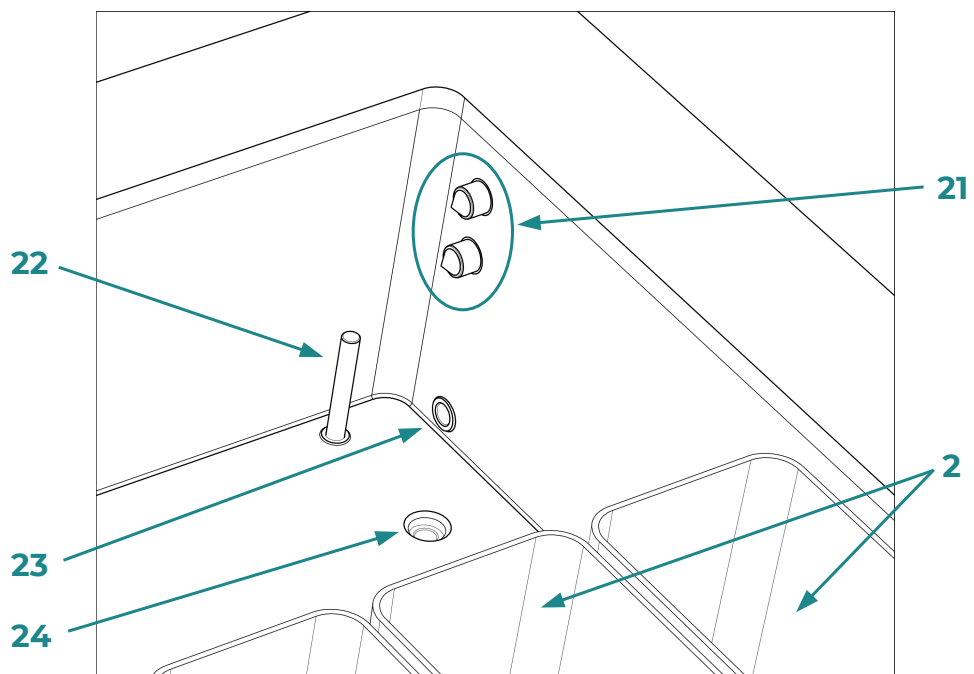

(b) Water level control

Figure 1.3: Details of the machine

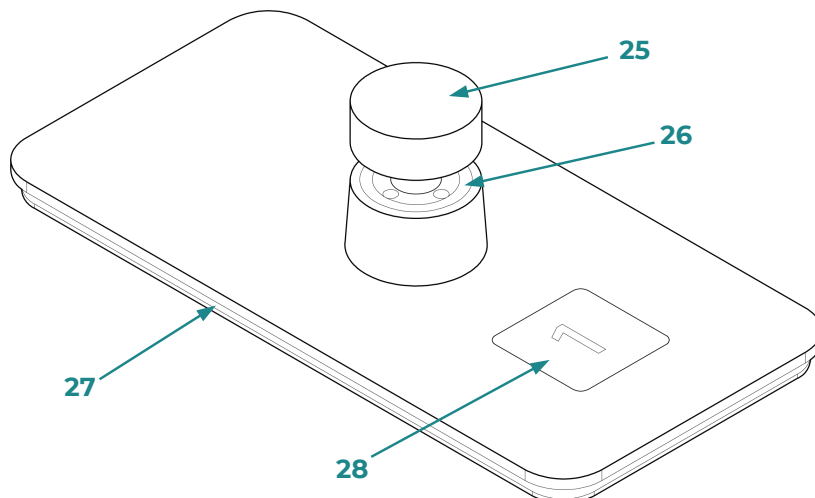

Figure 1.4: Chemistry container lid details

Elements of the machine:

- | | |
|------------------------------|-----------------------------------|
| 1. Water bath | 17. Waste outlet |
| 2. Chemistry containers | 18. Tank port connector |
| 3. Tank lock bar | 19. Tank plastic supports |
| 4. Overflow port | 20. Tank insertion guides |
| 5. Chemistry recovery faucet | 21. Water level sensors |
| 6. Adjustable feet | 22. Temperature sensor |
| 7. Display | 23. Water bath recirculation port |
| 8. Power LED | 24. Water bath inlet valve port |
| 9. "No-lights" mode switch | 25. Knob |
| 10. USB port | 26. Vent gasket |
| 11. Cooling fan vents | 27. Lid gasket |
| 12. AC socket | 28. Container number plate |
| 13. AC socket fuses box | 29. Tank lock bar latch mechanism |
| 14. AC socket ON/OFF switch | 30. Rotation inspection window |
| 15. Overflow outlet | 31. Manual drain faucet |
| 16. Pressurized water inlet | 32. Mechanical rotation gear |

On the front you will find the six chemistry retrieval faucets and the 7" touch display. On the back you will find the water inlet, the waste and overflow outlets and the AC power socket.

Looking from the top you will see the six chemistry containers aligned on the front edge on the machine, each with its own dedicated temperature sensor. Near the rear edge, on the left, you will see the tank connector port, the tank supports and the tank lock bar. On the right you will see the water bath temperature sensor, the water level sensors and the water bath recirculation port.

1.1.1 Containers lids

The machine comes equipped with six chemistry containers lids, numbered one to six. The numbering is there to prevent cross-contamination by accidentally placing the lids on the wrong containers. The lids are equipped with a gasket around the edge to prevent chemistry leaks. They also have a knob that can be screwed-in against another gasket to make the container airtight. The knob must be left completely unscrewed during regular use to allow air to get into the container when the pumps are running.

**WARNING!**

It's crucial to leave the knobs unscrewed during use! If they're left locked the pumps, when moving the chemistry, will try to pull a vacuum inside the container and will eventually stop pumping when they can no longer sustain the pressure. This will lead to less chemistry pumped into the film tank and development issues.

**WARNING!**

The six chemistry containers are not meant to be used as long-term storage bottles, even if the machine will be used to always execute the same process. Even if the lids can be made airtight, chemistry should not be left in the machine for more than 24 hours. We suggest removing the chemistry from the machine and put it back into dedicated storage bottles as soon as the processing session is over.

1.1.2 Disclaimer

Adel Srl cannot be, in any way, held responsible for damages to processed film or damages to other hardware caused by machine failures.

2. The tanks

There are two versions of the tanks. The older version is designed to work with machines equipped with magnetic rotation drive while the newer version is designed to work with the machines equipped with mechanical rotation drive. Most components of the tanks are in common between the two versions except for the bottom lid.

The two tank versions are not compatible with each other, that is the magnetic drive tanks cannot be used on machines equipped with mechanical rotation drive and mechanical rotation tanks cannot be used on machines equipped with magnetic rotation drive.

Apart from the differences between the two versions explained in the following sections, everything stated in section 2.3, in section 2.4 and in section 2.5 is valid for both versions.

If you ever need assistance or spare parts make sure to explicitly state which kind of rotation drive is your machine equipped with.

2.1 Magnetic rotation tanks

Tanks designed for magnetic rotation have a completely flat and relatively thin bottom lid (3), this is because the distance between the base of the inner column (7) and the magnets mounted on the motor outside the plastic walls of the water bath must be reduced as much as possible.

On the inside of the bottom lid there is only a non-moving metal pin that will engage with the bearing mounted into the base of the column.

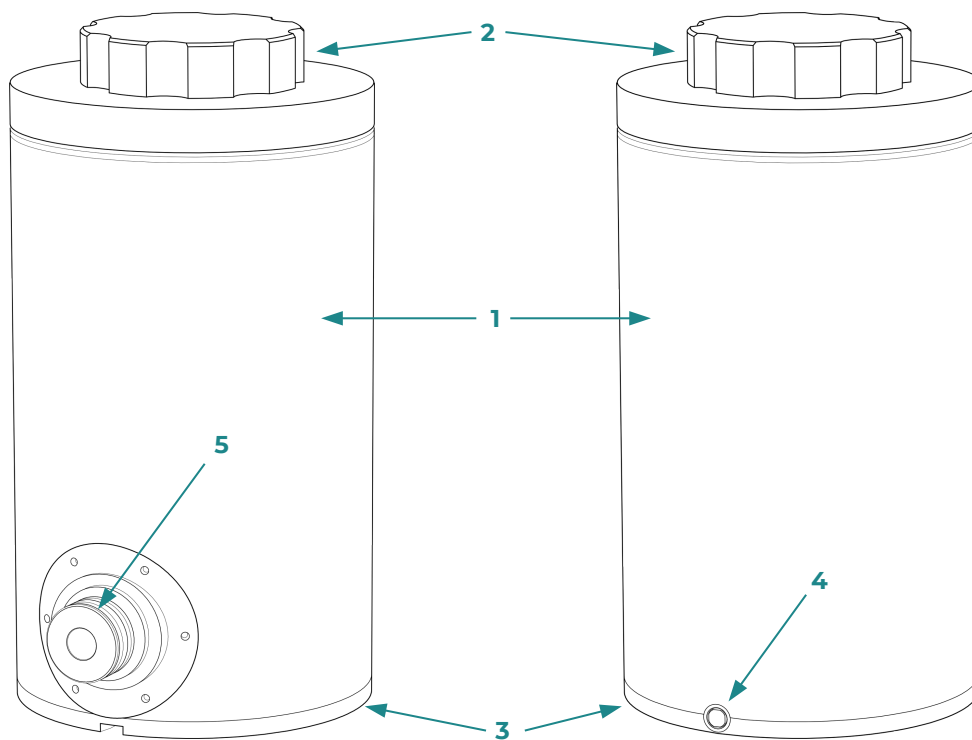
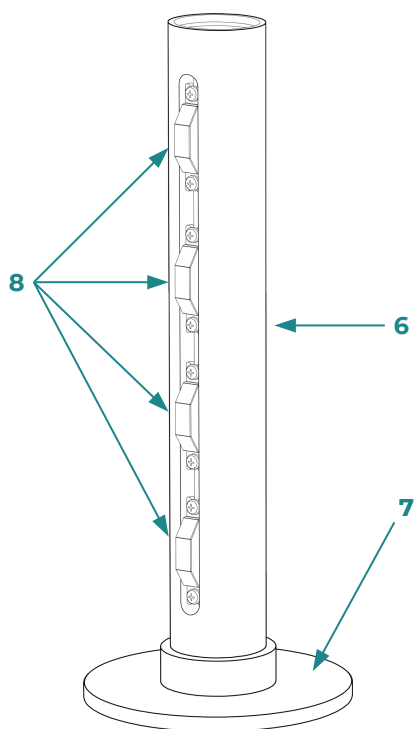

Figure 2.1: Magnetic rotation tanks.



Elements of the tanks:

1. Tank body
2. Tank top lid
3. Tank bottom lid
4. Tank relief valve
5. Tank connector
6. Inner column
7. Inner column base
8. Inner column spring-loaded plastic blocks

Figure 2.2: Inner column for magnetic rotation tanks.

2.2 Mechanical rotation tanks

Tanks designed for mechanical rotation look almost exactly like the ones designed for magnetic rotation, except for the bottom lid. Externally, a gear is mounted at the center of the bottom lid. Internally, the gear is connected through a shaft to a spindle that, in turn, engages with the inner column, transmitting the rotational movement to the film. The shaft is protected by shaft seals that ensure leakproof operations.

The inner column base is smaller and thinner. With this design embedded magnets are not needed, its only purpose is to prevent reels from falling down after they've been loaded. In place of the bearing it has a cross-shaped hole that fits together with a spindle on the bottom of the tank.

List of elements of a mechanical rotation tank, see Figure 2.3:

1. Tank body
2. Tank top lid
3. Tank bottom lid
4. Tank connector
5. Mechanical rotation gear
6. Inner column
7. Inner column base
8. Inner column spring-loaded plastic blocks

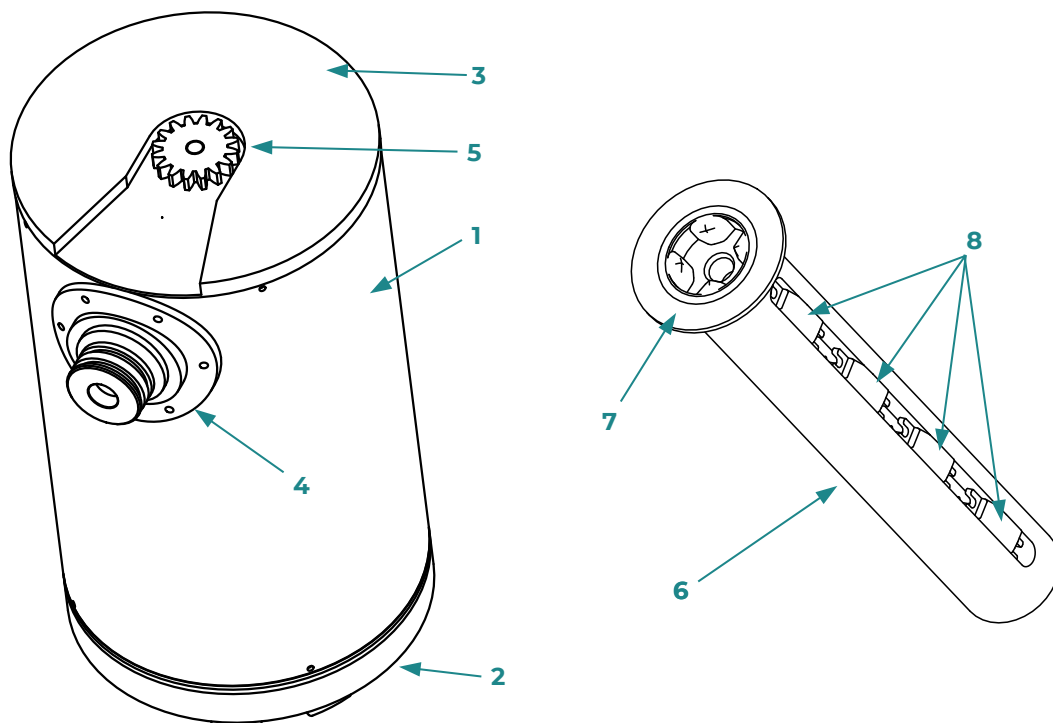

Figure 2.3: Mechanical rotation tanks.

2.3 Film capacity

Three different tank sizes are available and they are all compatible with this machine. For 35mm and 120 film development our tanks are compatible with Paterson reels, AP reels and Jobo 1500 series reels, they are **not** compatible with Jobo 2500 series reels. For sheet film development our custom reels are available for 4x5, 5x7 and 8x10 sheets.

Table 2.1 lists the processing capacity of each tank size.

Tank size	35mm	120	4x5	5x7	8x10
Small	2	1 - 2 *	-	-	-
Medium	4	2 - 4 *	2	1	-
Large	6	3 - 6 *	4	-	1

Table 2.1: Film capacity for each tank size

* The double capacity refers to Jobo 1500 reels, with them, it's possible to load two 120 rolls on the same reel without risking any overlap (using the red tab on the side). On the other hand, Paterson and AP reels don't have a built-in feature that prevents two 120 rolls from overlapping.

2.4 Required chemistry

The amount of chemistry that you will need to correctly process your film depends on tank size. While the film rotates inside the tank it must be intermittently submerged in the chemistry for part of its rotation cycle. Usually the chemistry level must reach the innermost loop of the film reel, this way even the part of the film that has been loaded on the reel first will make proper contact with the chemistry.

There are, however, some specific situations in which reaching the innermost loop of the reel is not necessary. Here is a list of such situations:

- If the reels in the tank are loaded with **only one** 120 roll each. In this case, since 120 rolls are shorter than 35mm rolls, the reel's spiral is only partially filled.
- If the 8x10 reel is used. In this case the only sheet loaded in the tank is very close to the outside of the tank so filling it up to the middle is not necessary.

In all the other possible combinations, the tank must be filled up to the middle, otherwise part of the film will not be properly submerged. Here are some examples of situations in which less chemistry can be used:

- a single 120 roll
- two 120 rolls on separate reels
- one 8x10 sheet
- three 120 rolls on separate reels

And here are some example of situations in which less chemistry **cannot** be used:

- a single 35mm roll
- one 35mm roll and one 120 roll
- one 35mm roll and two 120 rolls
- two 120 rolls loaded on the same Jobo 1500 reel

- one or more 4x5 sheets
- one or more 5x7 sheets

Situations in which less chemistry can be used are called “Low vol.” while the regular ones are called “Full”. Table 2.2 and Table 2.3 list the required chemistry amounts and fill/drain times for each combination of tank size and chemistry volume. Obviously, using more chemistry than needed will not be a problem.

Tank size	Full	Low vol.
Small	500 ml	250 ml
Medium	700 ml	350 ml
Large	1 L	550 ml

Table 2.2: Processing chemistry

Tank size	Full	Low vol.
Small	15 sec	8 sec
Medium	19 sec	11 sec
Large	25 sec	16 sec

Table 2.3: Fill and drain times



WARNING!

Make sure to check out subsection 4.5.1 before running a process using the low chemistry volumes listed in Table 2.2.

2.5 Loading the tanks

Loading our tanks is just as easy as loading any other daylight processing film tank, if you have used Paterson, AP or Jobo tanks before you will find this procedure very similar. We have designed and included with the machine what we call “film clips” to secure the film on the reels so make sure to read subsection 2.5.1 to see how they should be used.

The tanks are designed to be opened only from the top by unscrewing the top lid while the bottom lid is fixed in place. The inner columns used in the tanks all have spring-loaded plastic blocks whose function is to hold all the supported film reels in place and prevent them from slipping. These plastic blocks, by pushing outward, allow our tanks to use reels with different inner diameters. Thanks to these blocks it's possible to mix reels from different manufacturer in the same processing run.

The base of the inner column **must always** be placed in the tank facing the bottom lid. In the magnetic drive version the base contains magnets that are used to transmit the rotational movement from the motor to the film while in the mechanical drive version the base engages with a spindle that makes the film rotate.

In complete darkness, once the film is loaded onto the reels, insert the reels on the inner column one by one. Once the inner column is loaded, insert it in the tank, making sure that the base is facing the bottom lid.

If you are using magnetic drive tanks make sure that the metal pin on the bottom lid of the tank is inserted into the bearing on the base of the inner column base. If you are using mechanical drive tanks make sure that the cross-shaped spindle mounted on the tank bottom lid correctly engages with the base of the inner column, you can check this by rotating the column, if it's correctly inserted you will be able to feel a corresponding rotation outside the tank on the gear.

Align the pin mounted at the center of the top lid with the bearing at the top

of the inner column and screw the top lid onto the tank. Make sure to tighten the top lid firmly in place to avoid any leaks. You are now ready to load the tank into the machine.

**WARNING!**

Be careful when inserting the loaded tank column into the tank, especially when using the large tank with a full load (6x35mm rolls). If you accidentally drop the column in the tank it might hit hard on the metal pin or on the spindle on the bottom and get damaged!

2.5.1 Film retaining clips

To avoid any chance of film coming off the reels during processing we have designed what we call “film retaining clips” or “film clips” for short.

Having film unwinding from the reel during processing would be a disaster, not only because the film itself will almost definitely be ruined, but also because it might prevent the other reels to rotate correctly, effectively ruining a whole batch of films.

This is especially relevant for 120 film, given its larger area and, consequently, its ability to displace water or chemistry. 35mm film is less subject to this problem but to avoid any type of disaster we suggest using the film clips with 35mm as well.

Film clips must be placed at the beginning of the reel, where you insert the film, inside the reel guide. They are compatible with Paterson, AP and Jobo reels and the following instructions are valid for all three reel types. It might seem difficult to load them in the dark at first but you will get comfortable with it very quickly.

[An instructional video](#) is also available [our Youtube channel](#), if you are reading this manual as a PDF file you can directly click on the underlined links. A video explanation can be clearer than a thousand words sometimes.

Loading 120 film clips

1. Load the film on the reel as usual.
2. Place the outer edge of the film in the correct position (Figure 2.4):
 - For Jobo reels place the outer edge of the film between the side notches used to advance the film and the beginning of the spiral.
 - For Paterson reels place the outer edge of the film about 2 cm past the metal spheres.
3. Slide one side of the clip into the film guide on one side of the reel, make sure the small tab on the side of the clip fits into the opening on the side of the reel (Figure 2.5).
4. Bend the clip with your hand and slide its other side into the other film guide (Figure 2.6).
5. Slide the clip toward the beginning of the reel until the two small tabs on the side hit the end of the opening (Figure 2.7).

Loading 35mm film clips

35mm clips are different from the 120 ones, this is because it would not be possible to bend them in the reduced width of the reel.

1. Load the film on the reel as usual, make sure to remember to cut off the film leader.

2. Place the outer edge of the film as in the 120 film case (Figure 2.8).
3. Slide one end of the clip into the first opening on one of the sides of the spiral (Figure 2.9).
4. Rotate the clip and slide it under the film guides on both sides (Figure 2.10).
5. Slide the clip toward the beginning of the reel until the two small tabs on the side hit the end of the opening (Figure 2.11).

127 film

Film clips are available on request also for 127 film. They work exactly like the 35mm ones.

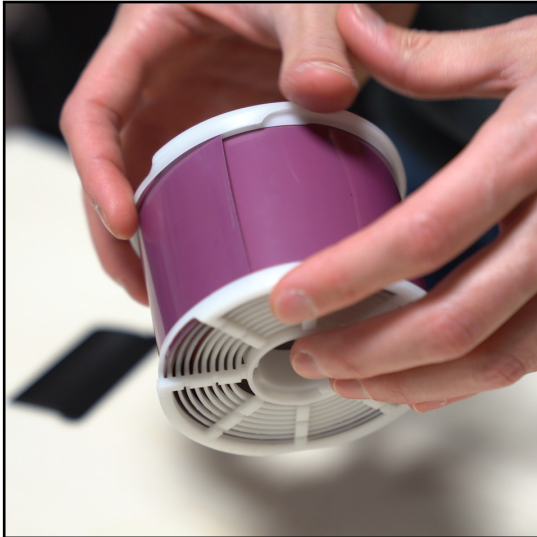

Figure 2.4: Initial film position



Figure 2.5: Slide the first tab of the clip into the film guide



Figure 2.6: Bend the clip and insert the other tab onto the other film guide

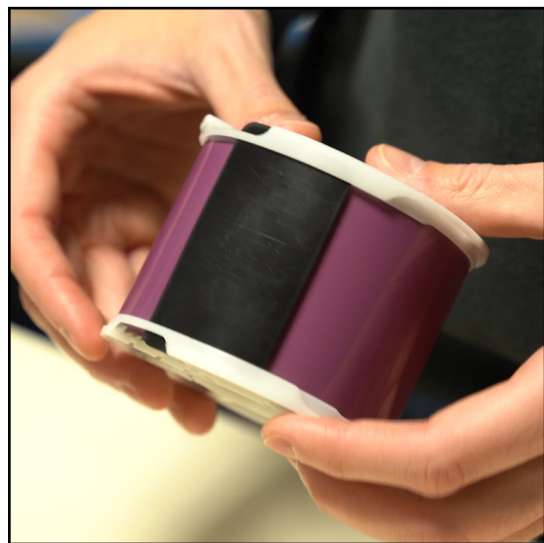

Figure 2.7: Finally, slide the clip toward the start of the spiral until the two small tabs on the side hit the end of the opening



Figure 2.8: Initial film position

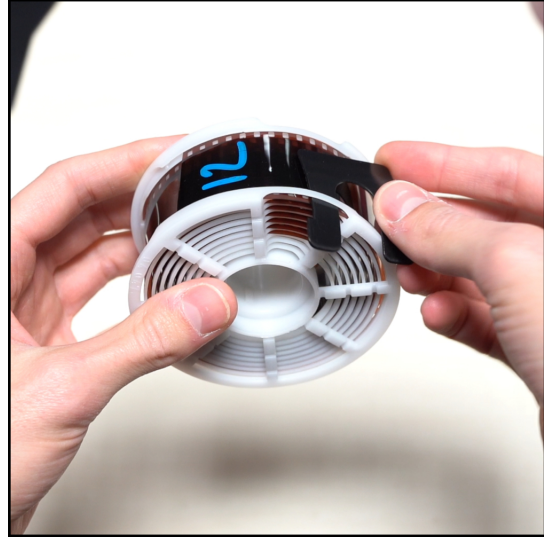

Figure 2.9: Slide the first tab of the clip into the film guide



Figure 2.10: Rotate the clip and slide the other side into the other film guide



Figure 2.11: Pull the clip toward the start of the spiral until the two tabs hit the plastic

3. Technical specifications

3.1 Size, weight and voltage

- Dimensions:
 - Width: 60 cm
 - Height: 28 cm
 - Depth: 51 cm
- Weight when empty: 19.5 kg
- Weight when fully loaded with full water bath and full chemistry containers: 35.5 kg
- Water bath capacity: about 10L (depending on which tank size is used)
- Input AC voltage: 220V or 110V depending on purchased model
- Input AC voltage frequency range: 50-60Hz
- Total power consumption: 900W

3.2 Electrical requirements

Our machine must be connected to a 220V or 110V socket depending on which model has been purchased, a label on the back of the machine displays the correct voltage. Be careful not to connect the machine to an AC voltage source different from the correct one. The socket on the back accepts power cords terminated with the standard IEC 60320 C13 connector.

Since liquids are involved, the outlet used to supply the machine must be grounded and must be protected by a GFCI (Ground Fault Circuit Interrupter). The socket on the back of the machine is also protected by two fuses. The fuses type depends on the AC input voltage:

- for the 220V AC version they are 6A, 250V, 5 x 20 mm slow-blow
- for the 110V AC version they are 10A, 125V, 5 x 20 mm slow-blow

3.2.1 Power backup

Our machine has no power backup features and, if you are located in an area where power outages and power instability are common, we recommend you to pair the machine with a UPS.

The machine draws, under maximum load, between 900W and 1000W, when the heating element is working at its maximum capabilities. For the rest of the time it doesn't draw more than 100W-200W and this includes normal processing and temperature control of an already hot water bath.

Given these figures we suggest installing a UPS with a capacity of 1500W.

3.3 Hydraulic requirements

Our machine doesn't have specific hydraulic requirements, it can work even if the water inlet on the back is not connected. In this case, for processes that require a water bath you will be instructed to fill it manually at the right time.

If you want to take advantage of the machine's capability of managing its own water supply, you can connect the "WATER IN" inlet on the back of the machine to a pressurized water source. This inlet has a standard G3/4" male thread and can be attached to anything with a G3/4" female thread, like common garden hose connectors. The pressure of the water source connected to the "WATER IN" inlet should be between 1.5 and 3 bar, which are typical values for a household hydraulic system pressure. Lower pressures might result in very slow filling times. The machine is internally equipped with a pressure reducer so slightly higher pressures should not be a problem.

The water supplied to the machine can be just regular cold water from your taps, the machine will be able to heat it up to the desired temperature in case of processes that require temperature control. You can also connect it to a hot water source but be careful, see section 4.5 about temperature control before making a decision.



NOTE

When trying to connect the machine water inlet make sure that you are not using anything with a tapered thread! Tapered threads, also called NPT threads, are very common in plumbing pipes and fittings, the water inlet thread on the other hand is straight so it's not compatible.

The "WASTE" outlet is used to dispose of rinse water and discarded chemicals, you can connect a tube to the outlet and redirect it to the desired location. Depending on regulations in your area you might not be allowed to dump used photographic chemicals down the drain, in this case you can redirect the output of the waste outlet to a bucket or a tank and properly dispose of it later.

The "OVERFLOW" outlet is connected to the overflow port located on the back of the water bath tub, if the water level rises too much it will overflow through this port. This will always be clean water so it's safe to dump it down the drain.

The chemistry recovery faucets on the front of the machine are directly connected to the corresponding containers and they can be used to recover the chemistry after processing. When the handle is in the horizontal position the

faucet is completely closed, when it is in the vertical position the faucet is completely open. The faucets **must** always remain closed, you should open them only when you need to recover the chemicals from the containers, after that close them again.

The “WASTE” and “OVERFLOW” outlets and the chemistry recovery faucets are equipped with quick-connect fittings that can accept a tube with an outer diameter of 10 mm, we highly recommend to use tubes with an internal diameter of 8 mm to avoid flow restrictions.

3.4 Installation

You can place our machine almost anywhere you want, you don't need a dark-room since the actual processing will take place inside a light-tight tank. Our machine is designed to tolerate splashes of water but **it is not** waterproof, when choosing its location make sure it will never be immersed in water or it will inevitably be damaged. To avoid any risk of electrical shock the machine itself and the power cord must never be immersed in water. Placing it into a dark-room sink is definitely not a good idea.

Anyway, the machine must be leveled to work correctly, dev.a has adjustable feet that can be raised or lowered to reach the desired configuration. A regular spirit level placed on the top plate can be used to adjust the four feet. Remember to check both directions!

The surface must be able to safely support the weight of the machine when fully loaded with water and chemistry. Since liquids are involved, splashes and spills will eventually happen, keep this in mind when choosing where to place the machine.

The “WASTE” outlet destination doesn't need to be at a lower level than the bottom of the machine since it is operated by a pump, on the other hand, the “OVERFLOW” outlet destination must be placed below the bottom of the machine since it works only using gravity.



Part Two: Operations

4	Using dev.a	33
4.1	Turning on the machine	
4.2	Turning off the machine	
4.3	Processes and steps	
4.4	Execution of a process	
4.5	Temperature control	
4.6	User interface	
4.7	Executing a process	

4. Using dev.a

4.1 Turning on the machine

To turn on the machine simply connect the socket on its back to the mains and flick the switch right next to it. The machine will then power up, a white led next to the display will turn on and, after a while, the machine will beep and the user interface will appear on the display.

4.2 Turning off the machine

To turn off the machine you can simply cut the power using the switch next to the power socket. The display, the power LED and, in general, the whole machine will immediately turn off. You can turn off the machine at any moment, just be careful to not turn it off while a process is running, you will not be able to resume the process afterward.

After turning off the machine, depending on the situation, you might want to follow the suggestions given in chapter 6 about cleaning the machine.

4.3 Processes and steps

The operating principle of our machine is based on the concept of “process”. A process is basically a list of steps that must be executed in order to develop photographic film. In the following chapters the word “positive” is used to refer to transparencies, or more in general, to refer to processes that produce a positive image.

4.3.1 Processes

A process is defined by the following elements:

- **Name:** a unique name assigned to the process, it's not possible to store two processes with the same name on the machine.

- **Film type:** negative or positive.
- **Film color:** black and white or color.
- **Temperature control:** can be enabled or not.
- **Process temperature:** the temperature at which the process has to be executed (meaningful only if temperature control is enabled), the valid range is 18-45 °C (64.4-113 °F).
- **Process temperature tolerance:** the tolerance applied to the process temperature value during the execution of the process itself, the valid range is 0.1-0.5 °C (0.2-0.9 °F).
- **Steps:** a list of processing steps (a process must have at least one step).
- **Favourite:** bookmark a process.

The film type and color **do not** have any influence on the execution of the process, this information is only used to classify processes using different categories. Processes can also be marked as “favourites”, you can mark as favourites the processes that you run most often, they will be easier to find in the user interface.

4.3.2 Steps

A “step” is one of the phases of a photographic process, for example the classic developer, stop and fixer phases are the three major steps of black and white development processes. In our case we also include rinse and pre-soak steps in this definition to treat everything uniformly. A step is defined by:

- **Name:** the name of the step (it cannot be empty).
- **Processing time:** how long the step will be, the valid range is from 1 minute to 2 hours.
- **Type:** the type of the step, it can be “chemistry”, “rinse” or “multi-rinse”.
- **Source:** where the water or chemistry will be taken from.
- **Discard after processing:** if the liquid must be discarded at the end of the processing time (in case of rinse steps the water will always be discarded).

Step types

We have three different step types, each with its own features. The step type will determine a few things: the allowed sources for the liquids, how the machine behaves while the step is being executed and if the chemistry will be discarded or not after processing.

- **Chemistry:** as the name suggests, a chemistry step is one of the steps of your process that involves chemistry or, more in general, something that is not plain water. Chemicals can only be taken from the chemistry containers and you will be able to choose if you want to discard the chemistry or if you want to recover it after processing.
- **Rinse:** a single rinse of the film inside the tank. In this case the tank will be filled with water and then drained after the step processing time. The rinse water can come from one of the containers or from the water bath. After the processing time has elapsed, the water is automatically discarded. This step type can be used for pre-soak steps or for quick washes in between chemistry steps.
- **Multi-rinse:** in a multi-rinse step the tank is continuously filled with water and then drained in cycles whose duration can be set in the configuration. In this case, since a large amount of water is needed, the only

allowed source for the rinse water is the water bath. Chemistry containers can contain enough water only for a single rinse. As with single “rinse” steps, water is automatically discarded after every cycle. If the total processing time is not a multiple of the duration of a cycle, the last cycle will be longer, in order to be over exactly at the end of the step processing time. This step type is particularly suited for final washes, where water should be frequently changed to make sure that the film is properly washed.

**NOTE**

A few important notes about processing steps:

1. the machine cannot know what kind of liquid is poured into the chemistry containers (or even if liquid is present at all!) so it comes down to the user to make sure that no mistakes are made and the containers are always filled with the right chemicals.
2. Be careful when using “Multi-rinse” steps if the machine water inlet is not connected to a water source. “Multi-rinse” steps, depending on their duration, use large amounts of water and a full water bath may not contain enough water to reach the end of the process.

4.3.3 Example

For example, suppose you have bought a generic C41 development kit that uses separate bleach and fix. It must be executed at 38 ± 0.2 °C (100.4 ± 0.4 °F) and the instructions from the manufacturer report the following steps:

- Pre-soak: 3 minutes
- Color developer: 3 minutes and 15 seconds
- Bleach: 1 minute
- Fixer: 2 minutes
- Final wash: 10 minutes in running water
- Stabilizer: 1 minute

Let's assume that chemistry can be reused many times so it must be recovered after processing.

This process might be saved on the machine as follows:

Process:

- Name: “C41 bleach+fix”
- Film type: negative
- Film color: color
- Requires temperature control: yes
- Process temperature: 38 °C (100.4 °F)
- Process temperature tolerance: 0.2 °C (0.4 °F)

Steps:

- Step 1:
 - Name: “Pre-soak”
 - Duration: 3 min
 - Type: rinse
 - source: Water bath
 - Discard after processing: yes

- Step 2:
 - Name: “Color developer”
 - Duration: 3 min 15 sec
 - Type: chemistry
 - source: container 1
 - Discard after processing: no
- Step 3:
 - Name: “Bleach”
 - Duration: 1 min 30 secs
 - Type: chemistry
 - source: container 2
 - Discard after processing: no
- Step 4:
 - Name: “Fix”
 - Duration: 2 min
 - Type: chemistry
 - source: container 3
 - Discard after processing: no
- Step 5:
 - Name: “Final wash”
 - Duration: 10 min
 - Type: multi-rinse
 - source: water bath
 - Discard after processing: yes

The stabilizer, or other wetting agents that produce foam, must be applied manually outside the machine, see subsection 4.3.4 for more information about this.

Similarly, you can create any process you like, you can even repeat chemistry steps if that makes sense in your specific case. The machine comes with just a few **generic presets** that should be intended as examples and starting points for further customization. We decided to avoid more specific and detailed presets for the following reasons:

- Even standard processes like C41 and E6 present some slight differences depending on the chemistry/kit manufacturer.
- Entering a new process is a very simple procedure that will not take more than 5 minutes.
- We want to encourage you to fine tune the processes in order to suit your needs and to produce the best results for your workflow.

4.3.4 Notes about film processing

Development times

Since this is a rotary film development machine, remember to adjust the development times according to the film and chemistry manufacturers specifications. Film manufacturers usually specify development times for both “intermittent agitation” and “rotary processing” (sometimes also called “continuous agitation”), when using this machine it’s important to use the times given for rotary processing. If no specific time is given for rotary or continuous agitation processing, a good rule of thumb is to reduce the intermittent agitation development time by 15%.

Re-exposure to light mid-process

Since it's not possible to "pause" a process halfway through, if you want to execute a reversal process that requires the film to be manually re-exposed to light, you can create two different processes, the first one will include the steps up until the re-exposure while the second one will include the steps after the re-exposure.

Wetting agents and stabilizers

Steps involving wetting agents, stabilizers or, more in general, chemistry that can produce large amounts of foam and bubbles, must be executed manually **outside** the machine. These steps should not be added to the process and, when processing is over, you can remove the tank from the machine, open the lid and pour into the tank the wetting agent you want to use, as you would with other daylight processing tanks. Foam and bubbles will not damage the machine itself but they will probably overflow out of their container and spill into the water bath or worse, into the other containers.

**CROSS-CONTAMINATION ISSUES**

If you want to run the same process more than one time in a row, that is without a complete cleaning cycle in between, make sure to add a relatively long multi-rinse step at the end of the process, with at least 4 water changes. This will provide a proper wash of the machine internal components and prevents cross-contamination issues caused by chemistry residues. Without a thorough wash you might find that fixer residues from the first run mix with the developer in the second run, effectively ruining it.

4.4 Execution of a process

Our machine splits the execution of a process in two different phases, in the first phase the machine performs some preliminary checks and waits for all the necessary conditions to be met, while in the second phase the machine executes all the processing steps in the correct order.

In the preliminary checks phase the machine will:

1. Check if the water bath requirements are met. If the process requires a water bath for temperature control or rinse steps the machine will wait until the water reaches the required level, otherwise, if the process doesn't require a water bath this check will be skipped.
2. Check if the temperature requirements are met. If the process needs to be executed at a specific temperature the machine will start heating the water bath and wait until the chemistry reaches the desired temperature. If the process doesn't require temperature control this check will be skipped.
3. Check if the tank is placed correctly inside the machine.
4. Check if film is rotating correctly inside the tank. This check is only performed on the machines that have a magnetic rotation drive, the ones equipped with the mechanical rotation drive don't have the corresponding sensor so this phase is replaced by a 10-seconds period in which the user can stop the process if something seems wrong.

If a problem is detected, for example the tank is not placed correctly in the machine, the user is notified and he's given two choices. He can ignore the

problem and choose to go on at his own risk (“skip”) or he can try to fix the issue and instruct the machine to check again if everything is alright (“check again”).

Skipping an error message is generally not a good idea, if there is a real problem the process will almost certainly end up with ruined film, lost chemistry or both, depending on the issue. The possibility of skipping an error check may help you in case you have a broken sensor that prevents you from using the machine. Let’s suppose, for example, that the tank presence sensor is broken. The machine will report the error telling you that the tank hasn’t been detected but, if you are sure that the tank is correctly placed inside the machine, you can skip the error and go on with the rest of the process.

In the second phase the machine executes all the processing steps. Once this phase is reached the machine will not and it will keep executing the processing steps. It wouldn’t make sense to stop the processing halfway through if an error is detected, the film might easily be ruined if processing is paused at the wrong time, so the machine goes on and stops only at the end of the process. If errors are detected during processing the user is notified with a message but the process goes on as planned. Possible errors that can be detected during process execution are, for example, film rotation errors and low water level.

Only the user can decide to interrupt the process in this phase. The process can be stopped immediately or at the end of the step that is currently being executed.

**NOTE**

Even if film rotation is not visible from the outside it’s possible to visually inspect it using the window on the left side of the machine. A metal plate with the Analogico logo is mounted on the back of the motor and allows you to have a visual feedback of how the rotation is going on. It must be a smooth and continuous movement, otherwise it means that something is interfering with the rotation inside the tank.

4.5 Temperature control

Our machine is equipped with all the necessary components required to heat the chemistry and to maintain it at a constant temperature throughout the execution of a process. The temperature control process doesn’t work by directly heating the chemistry, instead, it warms up a water bath that constantly recirculates and warms up the chemistry containers and the tank itself. This temperature control method might be slower than direct heating but gives us three advantages:

- the water used for the tempered water bath can also be used for pre-soak and rinse steps without affecting film temperature
- having a large amount of water at the correct temperature in the machine makes the whole process less subject to temperature variations
- the water used for the tempered water bath can also be used for a cleaning cycle when processing is over

Our machine allows you, for each process, to set a temperature between 18

°C and 45 °C (64.4 °F - 113 °F) and a tolerance between 0.1 °C and 0.5 °C (0.2 °F - 0.9 °F). The temperature control process will heat the water bath and the chemistry and **will start processing as soon as the following conditions are met:**

- The temperature of the container used for the first chemistry step of the process is within the target temperature \pm tolerance range.
- The water temperature is within 1.5 °C of the target temperature.
- The difference between the hottest and coldest chemistry containers involved in the process is less than 5 °C.

If, for some reason, the process does not use any of the chemistry containers, the temperature control process will only heat and monitor the water bath.

The machine monitors the container used in the first chemistry step because in all photographic processes, the first developer is the most critical and the most temperature sensitive step in the whole process. After this, the machine trusts the user not to put into the other containers chemistry that is at very different temperatures for the following steps.

Anyway, it's important to note that, since we only have heating capabilities, setting a process to run at a temperature lower than the ambient temperature will probably prevent it from running at all, in this case the only thing the machine can do is to simply wait, hoping for the chemistry temperature to drop. The simplest way to avoid this problem is simply to use chemistry that is colder than the target temperature and let the machine do the rest of the job. In case this is not possible you can always try to cool the water bath to sub-ambient temperature using external tools such as water chillers or ice bags, the machine will patiently wait for the temperature to drop or for the user to skip to the next phase.

If, after executing a high temperature process, you need to execute another one at a lower temperature (e.g., from 38 °C to 30 °C), the only way to do this is to drain the hot water from the machine, fill it again with cold water and restart the process from a lower temperature. Or, if you are not in a hurry, you can simply wait until everything cools down enough.

The machine can manage two different heating methods:

- **Regular heating:** The machine warms up the water bath at a temperature slightly higher than the target temperature and then maintains it until the first involved chemistry container reaches the target temperature. This method is slower, it's not possible to heat the water bath too much because otherwise the chemistry temperature will also rise above the target. You can speed up this process by connecting the water inlet on the back of the machine to a hot water source but you must be careful to set its temperature to be **not** higher than the target temperature of the process. If the water that comes in is too hot the machine will not be able to keep the chemistry temperature fixed at the target one and it will overheat.
- **Fast heating:** The machine keeps warming up the water bath constantly, as much as it can, even if the water temperature rises above the target one significantly. When the chemistry reaches the target temperature the heating stops and cold water from the water inlet is brought in to cool down the water bath. As soon as the water bath cools down to the target temperature the machine stops bringing in cold water and start to main-

tain the water bath temperature. This method is much faster than “regular heating” but a considerable amount of hot water is discarded from the waste outlet in the cooling phase. You should consider using this method only if, for some reason, you really need to shorten the heating time. Also, this method is available and works correctly only if the water inlet on the back of the machine is connected to a **cold** water source, otherwise it will not be possible to cool down the water bath. Since the water that gets discarded in the cooling phase is basically clean water, it can be recovered by temporarily redirecting the waste outlet to a bucket or to an external tank, this water can later be reused for other purposes.



NOTE

To correctly use the fast heating method it's important that the first chemistry container involved in the process is at a temperature that is at least 1 °C lower than the target temperature. If the container is above this threshold the fast heating phase will be skipped. Otherwise, the temperature of the chemistry might rise too much and above the target.

For example, Consider a generic process in which all 6 containers must be heated starting from a water and chemistry temperature of around 18 °C (about 64 °F). Table 4.1 shows the differences in heating time using regular or fast heating (only heating times are shown, processing times are not counted) and the amount of wasted water in case of fast heating.

Target	Regular heating	Fast heating	Wasted water
38 °C (100.4 °F)	72 min	44 min	6-7 L
32 °C (89.6 °F)	50 min	32 min	6-7 L
25 °C (77 °F)	38 min	19 min	6-7 L

Table 4.1: Regular heating and fast heating comparison

These times may vary depending on ambient temperature, water bath initial temperature and chemistry initial temperature. The purpose of this table is only to give you a rough estimate of the advantages of the fast heating method.

By default, the machine will use the “regular heating” method, you will be able to switch to the “fast heating” method right before starting a process (and only if the water inlet on the back is connected).

4.5.1 Low chemistry volumes and temperature control

Due to their position and shape, temperature sensors need to be fully submerged in order to provide a reliable temperature reading. If only the lower part of the sensor is submerged in chemistry then, the temperature reading will actually be some sort of average between the chemistry temperature and the air temperature.

500ml is enough to fully submerge the sensor so this is an issue in only two “Low vol.” cases, those of the small and medium tanks, which require 250ml and 350ml respectively. If you intend to use these two amounts of chemistry in a process that requires temperature control, make sure to fully cover the sensors.

The machine will then go on and use the correct amount and, at the end of the process, the remaining chemistry can be recovered from the containers.

The same is true also if you want to use the temperature sensors in processes that are not temperature controlled, for example if you want to check the temperature of the developer before executing a black and white process.

4.5.2 Important notes about temperature control and water management

When the machine is connected to a pressurized water source, the water level is constantly monitored and, when necessary, more water is let in by the machine. In this case the temperature control process has no problem because all the water it needs is always present in the water bath.

On the other hand, if the water inlet is not connected and the water bath is filled manually before starting the process, there is the risk of running out of water mid-process. This might easily happen if the process contains many rinse steps or a long multi-rinse step. If this happens, as soon as the water flow stops in the water recirculation circuit, the heating control process must be suspended because the pump cannot run dry and the heating element should not overheat.

If this happens the machine will:

- suspend the heating process
- display a warning message on the user interface (shown in Figure 4.1)
- play a warning sound every 15 seconds

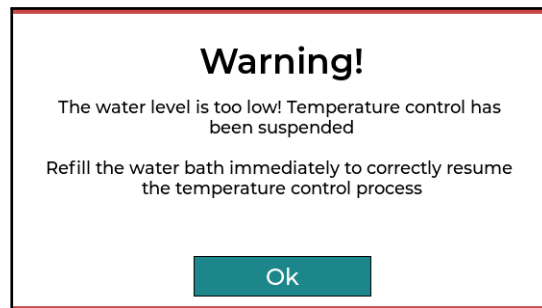

Figure 4.1: The warning dialog that will be displayed when there is not enough water to run the temperature control process

In this case the user should refill the water bath as soon as possible to allow the process to resume. The machine will try to restart the water pump and the whole temperature control process:

- every 2 minutes or
- if one of the water level sensors is active

In both cases the pump will try to restart ten times to allow air bubbles to be displaced and to refill the water recirculation circuit. If the machine cannot resume the temperature control process it will stay in the suspended state.

Note that even if temperature control gets suspended, the process itself will keep going, it won't be suspended. Given the complete freedom that the user has in setting up a process, the machine can run out of water at any time and we cannot risk suspending the process during one of its critical phases.

**WARNING!**

The above **does not** apply if the user skips the “water is not recirculating” error. In this case the machine has to assume that there is an issue with the flow sensor and this also means that it’s not possible to suspend the temperature control process if/when it will run out of water.

This is especially relevant if the machine is not connected to a water source and the user refills the water bath manually. **The water pump must not run dry! Pay attention!**

4.6 User interface

After the splash screen you will be presented with the main interface. It has three different tabs (Processes, Configuration and Tools) that can be selected by clicking on the corresponding icon on the left of the screen.

4.6.1 Main interface - Processes tab



Figure 4.2: The “Processes” tab

Shown in Figure 4.2, in this tab you will find the list of processes stored on the machine sorted in alphabetical order. For each process some essential information will be displayed, such as its name, if temperature control is required and the type and color of the film it is supposed to develop. If a process requires temperature control the temperature is displayed near the thermometer icon otherwise the thermometer icon is crossed out and no temperature is displayed.

By clicking on one of the processes in the list you will move to the process detail view. You can add a new process by clicking on the “plus” icon in the top right corner. The interface will change to show an empty process edit view.

Main interface - Process list filtering

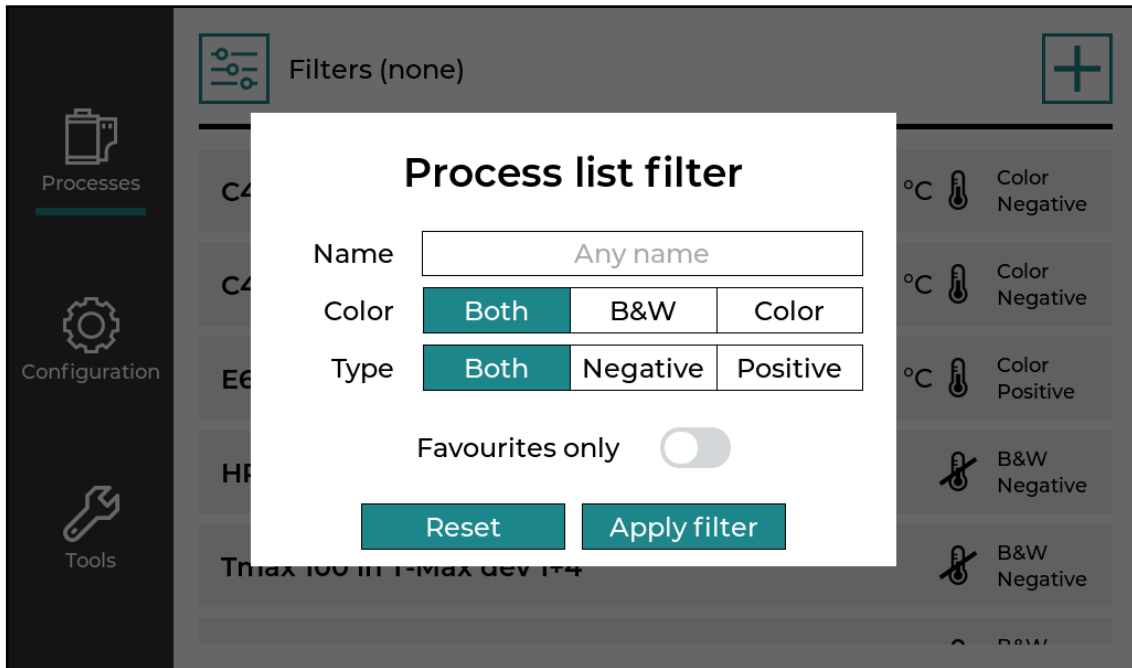

Figure 4.3: The process list filter dialog

The list can be filtered in case you need to find a specific process. In the top left corner there is a “Filter” button, clicking on it will display the filter dialog, shown in Figure 4.3. In this dialog you can set a combination of filters that will be applied to the list, you can filter by:

- Process name: processes whose name contains a specific string will be shown.
- Film color: you can choose to show only black and white or color processes.
- Film type: you can choose to show only negative or positive processes.
- Favourites: you can choose to show only processes that are marked as “Favourites”

Once you have set up the filters you can click on the “Apply filter” button and the list will be refreshed. The label near the “Filters” button will also be updated to show, between parenthesis, how many filters are currently applied to the list. Clicking on the “Reset” button in the filter dialog will disable all filters, effectively showing all processes.

4.6.2 Main interface - Configuration tab

In the “Configuration” tab you can find the global settings of the machine, they will be applied for every process executed by the machine. If you are not sure of the meaning of some of these settings, a small question mark icon can be clicked to show a quick help guide related to the setting.

This tab is split in two different screens, the main configuration and the advanced configuration. You can switch between them using the button at the bottom right of the screen.

The main configuration screen, shown in Figure 4.4, contains the following settings:

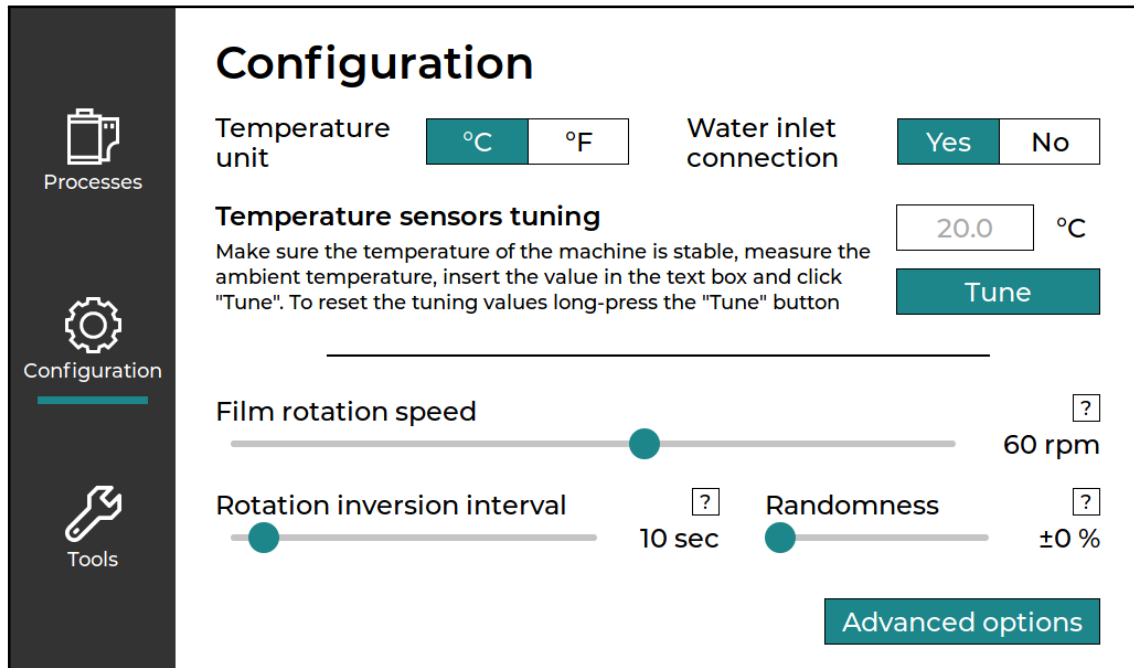

Figure 4.4: The main “Configuration” tab

- The unit used to display temperatures, Celsius or Fahrenheit.
- Water inlet connection, set if the machine is connected to a pressurized water source or not.
- Temperature sensors tuning.
- Film rotation speed (in RPM).
- Interval for rotation direction inversion (in seconds) and interval randomization percentage.

The advanced configuration screen, shown in Figure 4.5, contains the following settings:

- Persistent sound alarms.
- Process autostart.
- Multi-rinse cycle duration, adjustable in 30 seconds steps between 1 minute and 3 minutes.
- Overlap percentage between filling and draining times and processing times.



NOTE

The machine has no way of knowing if the water inlet is connected or not so, to ensure everything works correctly, it is necessary to manually set this.

Temperature sensors tuning

All the temperature sensors are factory calibrated using a precision thermometer, but still, they are not perfect. They might report slightly different values and their readings might drift over long periods time. To avoid these issues it is possible to adjust their values using an external trusted thermometer. The tuning procedure is very simple:

1. Let the machine temperature stabilize, if you have just finished a process

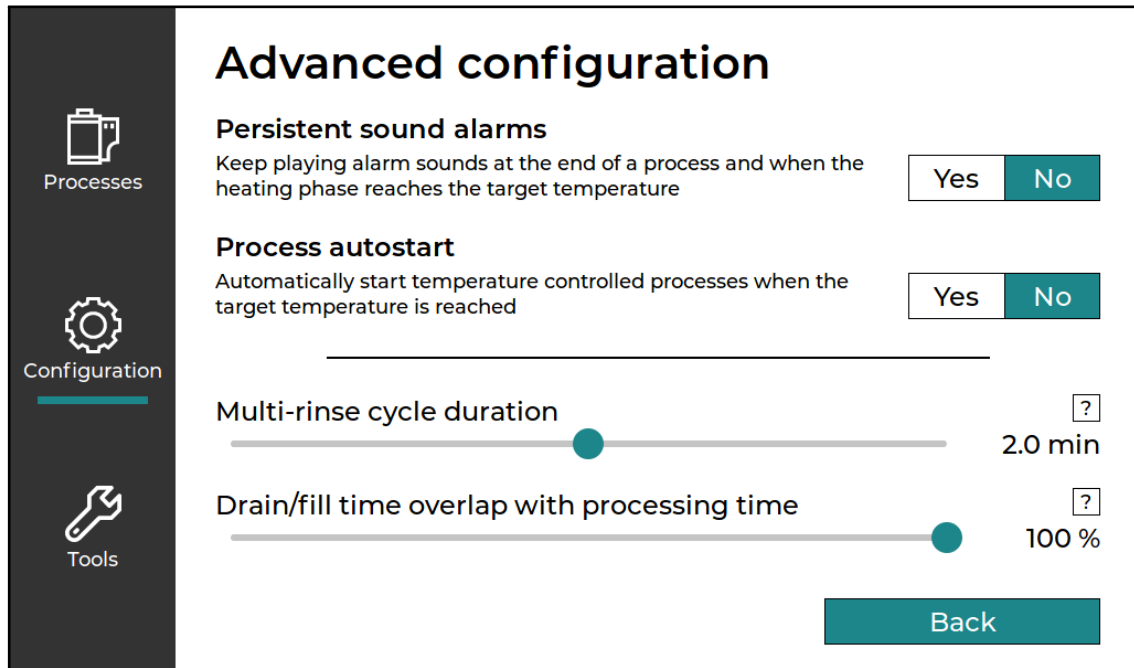

Figure 4.5: The advanced “Configuration” tab

clean the machine and wait some time to allow the machine temperature to be the same as the ambient temperature.

2. Make sure that all the sensors are not in contact with water or chemistry, in other words, make sure that they are measuring the current ambient temperature.
3. Place your trusted thermometer near the machine and make sure that its probe it’s not in contact with anything other than the air.
4. Take a reading of the ambient temperature on the external thermometer.
5. Enter the ambient temperature value in the text area and click on the “Tune” button. A message with the result of the tuning procedure will appear on the screen.

You don’t need to do this every time you use the machine, tuning the sensors once every two or three months or after long periods of inactivity should be perfectly fine.

If, for any reason you need to reset the temperature sensors tuning values you can long-press the “Tune” button and click on the “Yes” button on the dialog that will appear.

Film rotation parameters

With this machine you can set three different parameters regarding film rotation:

- **Rotation speed:** this is exactly what it sounds like, the speed, expressed in revolutions per minute, in the 20 rpm to 90 rpm range.
- **Inversion interval:** the amount of time for which the film will rotate in one direction before switching to the other, adjustable in the 5 sec to 60 sec range.
- **Inversion interval randomization:** This parameter will allow you to add a random variation to the inversion time to ensure a completely even de-

velopment. For example, if the inversion time is set to 10 seconds and the randomization value is set to $\pm 10\%$, the actual inversion time will be different for each inversion and its duration will range from 8 seconds to 10 seconds.

Process autostart

In case of temperature controlled process it's possible to choose if the machine, once the target temperature is reached, must wait for user confirmation or not before actually starting the process.

If "Process autostart" is set to "No", when the target temperature is reached the machine will play a sound, show a message and then it will wait for the user to start the process by clicking on the corresponding button.

Persistent sound alarms

The machine plays a specific sound when a process is over in order to notify the user. If this option is set to "Yes" the machine will keep playing the sound every 10 seconds until the user clicks on the user interface.

The sound played when the target temperature is reached will also be played every 10 seconds if this option is active.

Multi-rinse cycle duration

With this setting it's possible to set the duration of a single multi-rinse cycle (not the whole step). The appropriate duration depends on the tank that will be used. For example, when using a large tank, 1-minute cycles might be too short given the long fill and drain times. On the other hand, when using a small tank, 3 minutes cycles might be too long and less effective. Usually, 2 minutes, which is also the default, can be a good compromise for all situations.

Fill and drain times overlap

Filling and draining the tank can't be done instantaneously and inevitably take some time. The overlap percentage between filling and draining time and processing time lets you choose how much of the filling and draining time must be considered as part of the processing time of each step (the time you set for each step of the process). For example, if filling and draining the tank takes 20 seconds and the processing time for a hypothetical step is 60 seconds, depending on the overlap percentage we might have the following situations:

- Overlap 0%: filling takes 20s, processing takes 60s and draining takes 20s, filling and draining times are not counted as processing time.
- Overlap 50%: filling takes 20s, processing time is reduced to 40s and draining takes 20s, 10s of filling and 10s draining (50% of their time) are counted as processing time.
- Overlap 100%: filling takes 20s, processing time is reduced to 20s and draining takes 20s, all 20s of filling and all 20s of draining (100%) are counted as processing time.

As the overlap percentage grows more and more of the filling and draining time ends up as counting as processing time.

Figure 4.6 shows, in a schematic way, how the overlap percentage parameter influences process execution. Fill and drain times are represented in green.

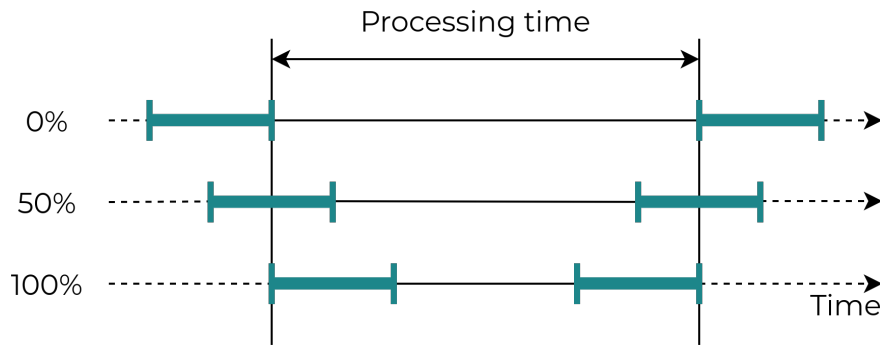

Figure 4.6: Schematic representation of the different overlap possibilities

By comparison with manual film processing, you can think of this option as the moment in which you start the timer when pouring chemistry into the tank:

- Setting the overlap to 0% is the same as starting the timer *after* you have poured all the chemistry into the tank and stopping it *before* pouring it out.
- Setting the overlap to 50% is the same as starting the timer halfway thorough the pouring, both when filling and draining the tank.
- Setting the overlap to 100% is the same as starting the timer when you start pouring the chemistry into the tank and stopping it when you have finished pouring the chemistry out of the tank.

We think that filling and draining time should be completely included into the processing time, that is, setting this parameter to 100%. This is because the development, (or, more in general, the action of the chemistry) starts as soon as the chemistry touches the film. Anyway, you are free to experiment with this parameter to find out which value works best for you and your processing.

4.6.3 Main interface - Tools tab

The “Tools” tab, shown in Figure 4.7, is split in four sections. In the “Maintenance” section you can find the three special processes: the cleaning process, the draining process and the self-check process. You can start them by clicking on the corresponding “play” icon on their right, more on these special processes in chapter 6.

At the bottom you can find the “Statistics” section. It contains some information about your machine usage.

In the right column, at the top, you can find the “Utilities” section. Here you have two green boxes with the “Import” and “Export” functions. To know more about these functionalities see section 7.2.



WARNING!

Be careful with the import function! By importing processes and configuration from a USB drive you will completely overwrite the current configuration of the machine and the operation cannot be undone.

At the bottom you can find the “Software” section. Here you can see the

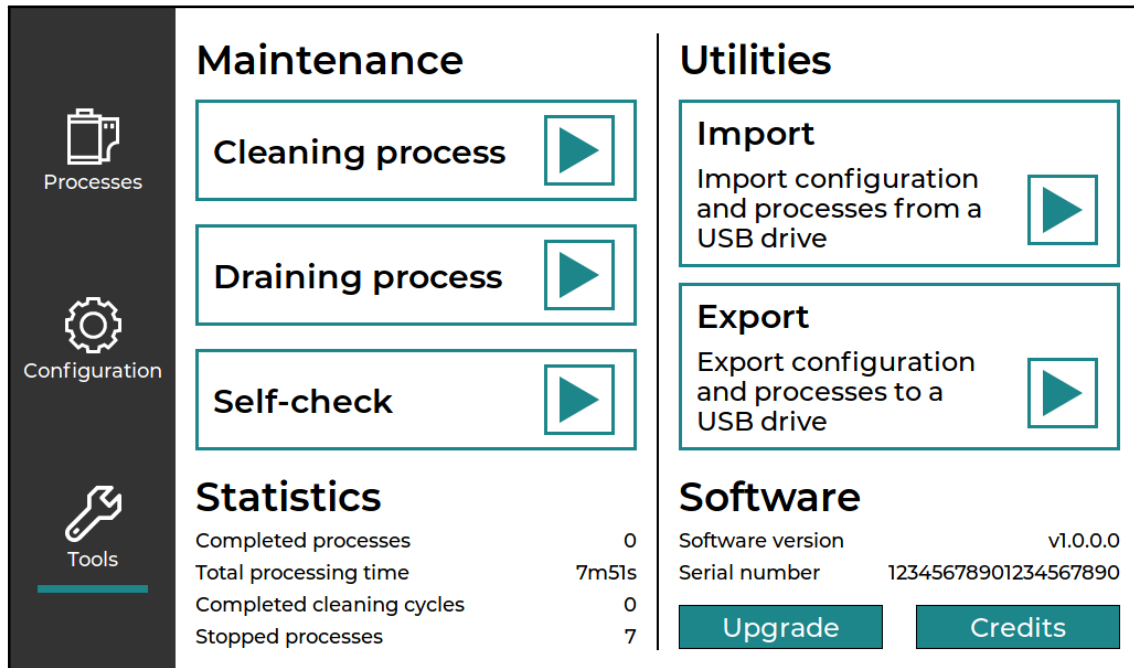

Figure 4.7: The “Tools” tab

serial number of the machine and the version number of the installed software. The “Upgrade” button will open a dialog that will start the software upgrade procedure. See section 7.1 for a detailed description of the upgrade procedure.

4.6.4 Process detail view

In the “Process detail” view, shown in Figure 4.8, you can see all the details of a process, at the top you have the process name, on the left you have the steps list and on the right you can see other properties of the process, such as temperature control, target temperature and if the process is marked as favourite.

In the steps list, for each step, from left to right you can see:

- The step type, distinguished by a specific icon:
 - Chemistry
 - Rinse
 - Multi-rinse
- The source of the step (“C1”, “C2”, etc. for chemistry containers and “WB” for water bath)
- The step’s name
- The step’s processing time

It is possible to create a copy of the process by clicking on the clone button in the top right corner, a copy of the process with the same name with “(copy)” appended at the end will be immediately created.







At the bottom right you have four buttons:

- “Back”: go back to the process list
- “Edit”: enable process editing
- “Delete”: delete the process
- “Play”: start the process

E6 six baths



Steps:

	C1	First developer	6m30s
	WB	Wash	2m00s
	C2	Reversal	2m00s
	C3	Color developer	6m00s
	C4	Pre-bleach	2m00s
	C5	Bleach	6m00s

Info:

For color positives

Temperature control: yes

Temp: 38.0 ± 0.3 °C

Favourite: yes

Total steps time: 34m30s









Figure 4.8: The “Process detail” view

4.6.5 Process edit view

Clicking on the “edit” button will transform the view to enable process editing, see Figure 4.9. At the top, the process name will turn into an editable text area, on the right, process details will be replaced by various widgets and the “Edit” button will be replaced by a “Save” button. Now, clicking on the “Back” button will go back to the process detail view.

The steps list will change as well. On the right of each step two arrows will appear, they can be used to change the order of the steps and move the corresponding step up or down. Clicking on one of the steps or on the “Add step” button will open the step editing dialog, shown in Figure 4.10. In this dialog you can change everything that regards the step: name, duration, type, source and if the chemistry should be discarded after processing. You can also delete the step using the dedicated button.

Near the source drop-down you can see the current temperature of the selected container. This can be very useful in case of black and white negative processes that are not temperature controlled but are temperature sensitive. In such cases you can pour the developer chemistry into the corresponding tank, open the step edit dialog and read the temperature of the developer, then you can adjust the processing time according to the film manufacturer specifications. However, make sure you carefully read subsection 4.5.1 before executing a process.

Remember that some limitations apply to the step’s properties:

- the name cannot be empty
- the duration is limited between 1 minute and 2 hours
- chemistry steps cannot have the water bath as source
- multi-rinse steps can only have the water bath as source
- in rinse and multi-rinse steps the water will always be automatically dis-

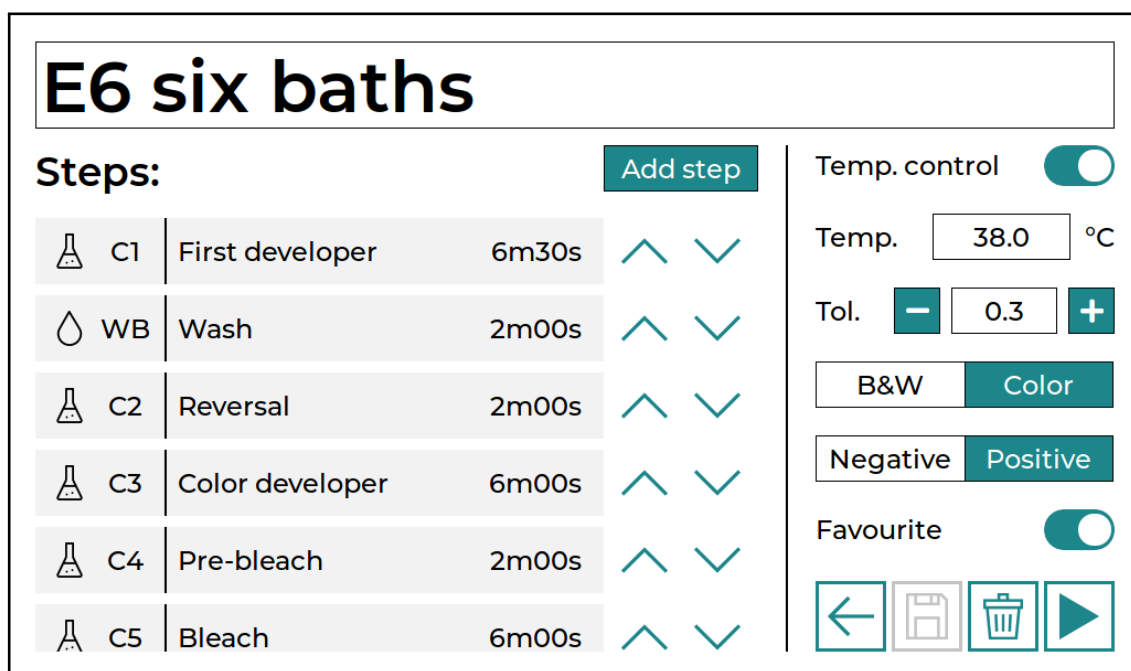

Figure 4.9: The “Process edit” view

carded after processing

When you are done editing a process you can click on the “Save” button to save it to permanent storage, a dialog will show the result of the operation.

Clicking on the “Play” button while editing a process will start the process as usual but will also automatically save it. It’s not possible to execute a process that has not been previously saved.

4.6.6 Process execution view

After clicking on the “Play” button in the process detail or edit view you will be brought to the “Process execution” view. This is composed of various different sub-views.

Tanks size selection view

The first view is the tank size and chemistry amount selection view, shown in Figure 4.11. Before starting the process the machine needs to know which tank size will be used and if the amount of chemistry can be reduced. While selecting the tank size and chemistry amount a small label right below the selection buttons will inform you about the required amount of chemistry for the current configuration. See section 2.4 and subsection 4.5.1 for a detailed explanation and some warning about the situations in which less chemistry can be used.

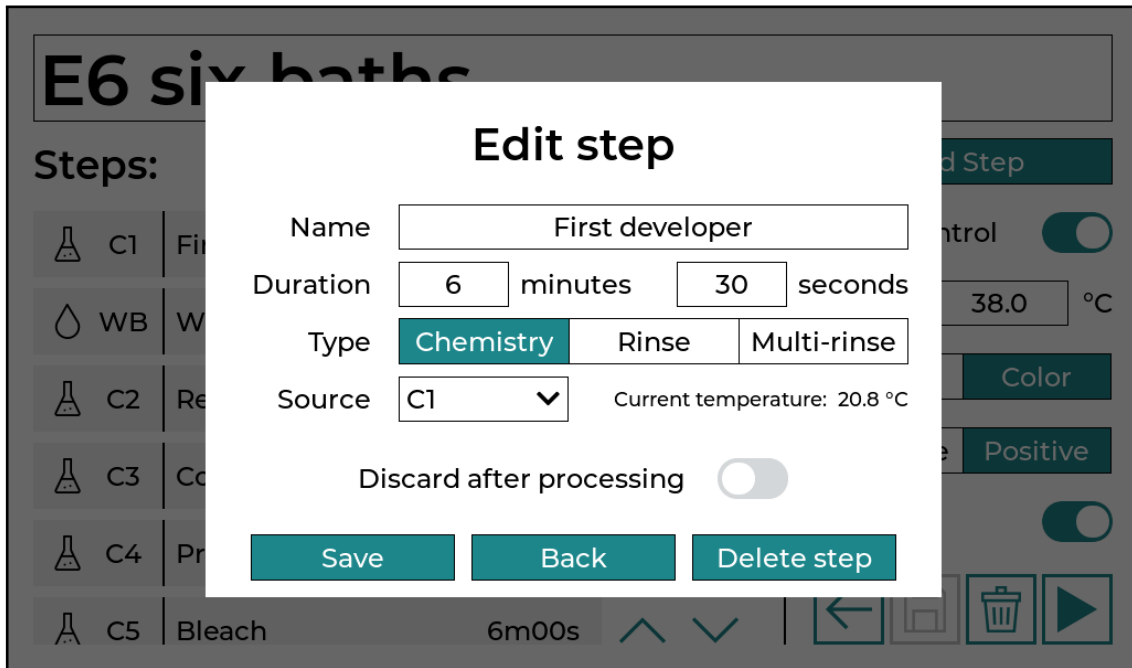

Figure 4.10: The “Step edit” dialog

**WARNING!**

Choosing the correct tank size and chemistry amount is extremely important! This will determine fill and drain times. Since this a rotary film development machine it's crucial to pump the right amount of chemistry to completely submerge the film into the tank. Starting a process using the wrong parameters might lead to uneven development since parts of the film may not be properly submerged.

Special processes such as the cleaning and draining processes, require the tank to **not** be in the machine, in this case a message will inform you about this.

Below the tank size and chemistry amount selection buttons you will also see the “Enable fast heating” switch. If the process doesn't require temperature control or if the machine's water inlet is not connected this option will not be available and the switch will be disabled. If you turn on the switch, instead of *regular heating*, *fast heating* will be used during the process. See section 4.5 for a detailed description of the fast heating procedure.

Once the correct tank size is selected the process can be started by clicking on the “Start!” button.

After starting the process the machine will begin with preliminary checks. You will be presented with three different views depending on process requirements:

1. First it will check the water level and fill the water bath.
2. Then it will move on to heating the chemistry.
3. Finally, it will check if the tank is in position and then will check if the film inside the tank is rotating correctly.

These checks are always displayed on the left of the interface and they represent what the machine will do before starting the actual processing. Checks

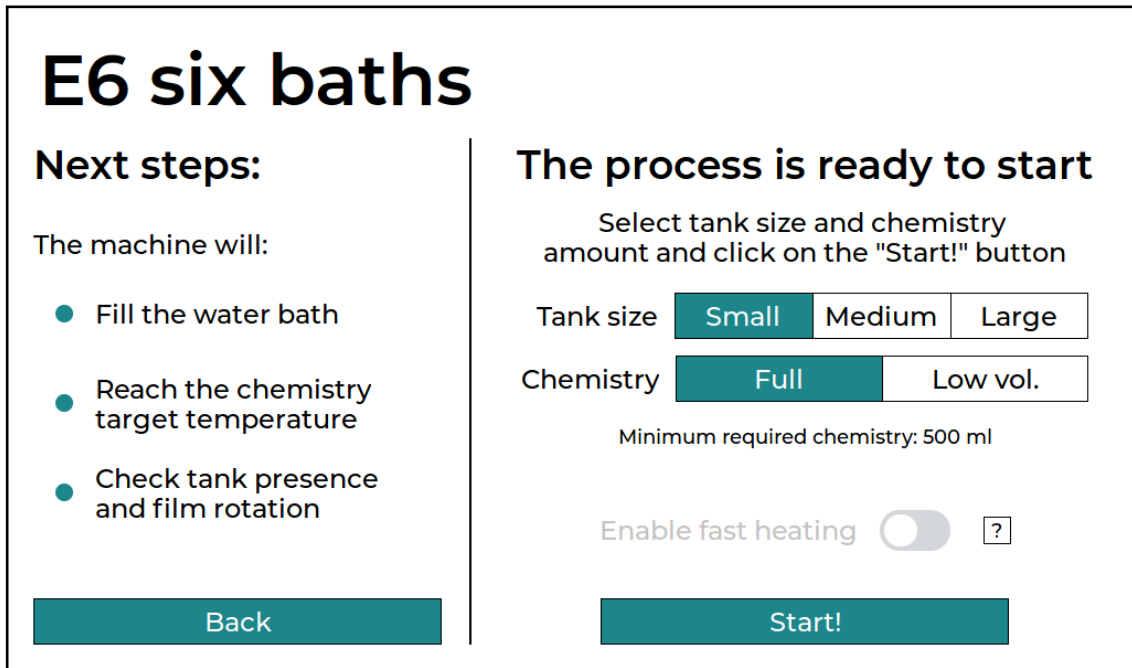

Figure 4.11: The “Tank selection” view

1 and 2 might be skipped if they don't make sense for the current process.



WARNING!

Before starting with the preliminary checks, a dialog will remember you to lock the tank in place.

Locking the tank using the lock bar is extremely important. The lock bar not only prevents the tank from floating, it also opens the tank relief valve to let air in and out. Without opening the relief valve the pressure inside the tank will constantly increase during processing, preventing the chemistry pumps to work correctly.



NOTE

Tank size choice is persistent across reboots. The last selected one will also be selected the next time you run a process. If you always use the same tank size you will not need to worry about selecting the correct one every time you run a process.

Water bath filling

In the water bath filling phase the water must reach the correct level, depending on how the machine is set up, this may happen automatically (if the water inlet is connected) or it may be done manually. The machine displays the needed instructions in this phase, as shown in Figure 4.12.

In case you're filling it manually using a jug or a bucket, there are two water level sensors inside the machine that indicate which level the water must reach. If the tank is already placed inside the machine the water must reach the top sensor, otherwise the bottom sensor. This is necessary to prevent the water to

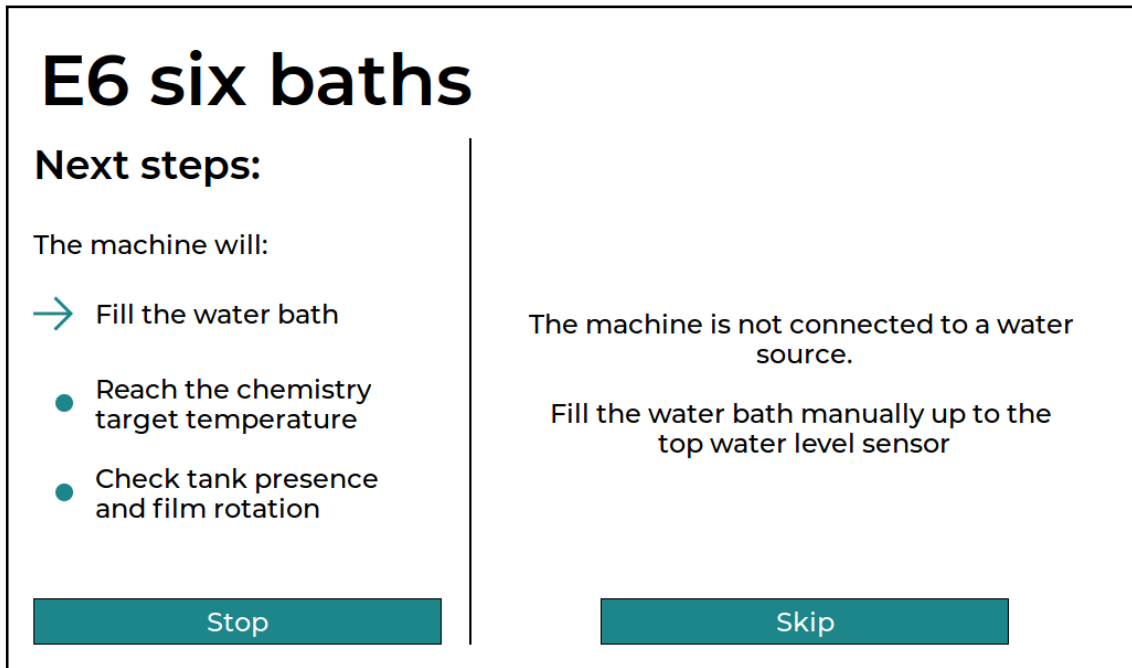

Figure 4.12: The “Water bath filling” view

overflow when the tank will be inserted in the machine. In any case you will see a message on the display that will inform you about the correct sensor to reach.

If the water inlet is connected to a pressurized water source everything happens automatically, the machine knows which sensor must be reached and you don't have to do anything.

When the correct water level is detected the machine moves to the next phase automatically. Using the “Skip” button you can (at your own risk) move to the next phase before the water reaches the correct level.

Water bath heating

When the water bath is full the machine starts heating the water which, in turn, heats the chemistry. On the screen, as shown in Figure 4.13, you will see the current values: the target temperature, the water bath temperature and the chemistry temperature.

When the chemistry temperature reaches the target one the machine can move to the next phase. If the “Process autostart” option is set to “Yes” in the configuration the machine will automatically move to the next phase, otherwise it will display a message and will wait for user input before going on.

At the beginning of the heating phase the machine will try to start the water recirculation pump. If, for some reason, there isn't enough water in the machine, it might not be able to correctly detect water recirculation. In this case the heating process won't start because without flowing water it's not possible to heat the chemistry.

If you have filled the water bath manually, the water recirculation circuit may not be completely filled and priming the pump may require some tries. If, at the beginning of this phase, you hear the water pump starting and stopping it's because the machine is trying to remove the air in the circuit and prime the

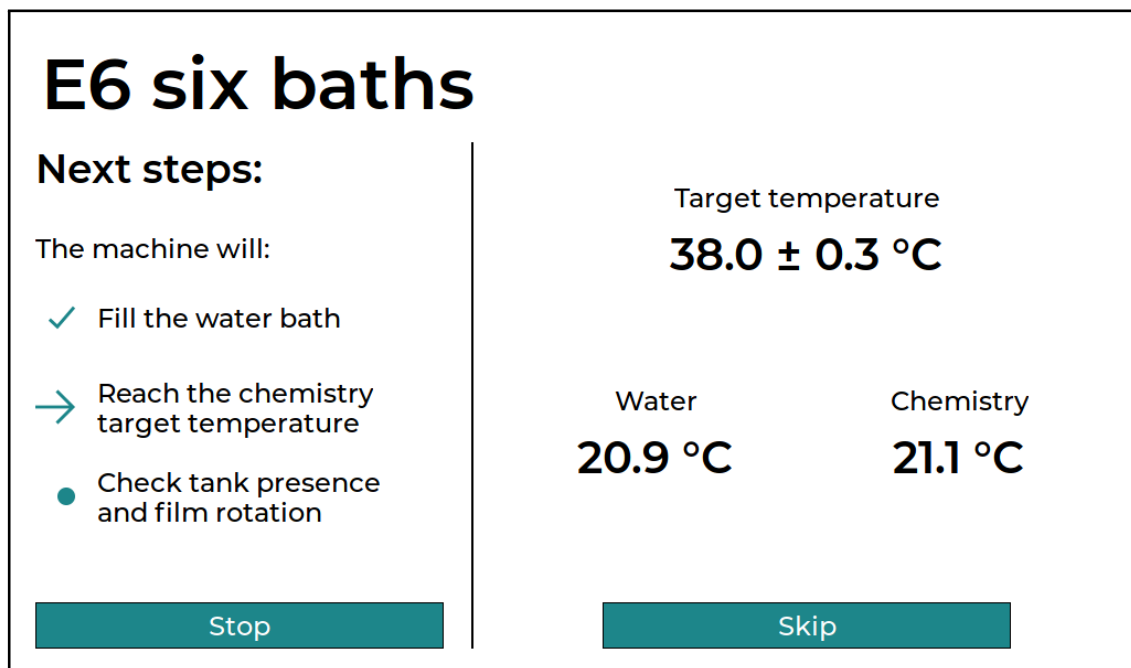

Figure 4.13: The “Water bath heating” view

pump. After several tries, if the machine hasn't been able to start, you will see a message on the screen telling you that the water is not recirculating.

It is also possible to manually help the machine in priming the pump. You can fill a 10ml syringe with water and empty its content directly into the recirculation port in the corner of the water bath, near the temperature sensor. In Figure 1.3 the recirculation port is marked with number 23. You can do this at any time, both when the pump is off and also when the pump is trying to start. If the content of one syringe is not enough you can repeat the operation until the pump is able to start.



WARNING!

It's possible to skip the error that tells you that water is not recirculating but be very careful! Do it only if you are sure that the issue comes from the flow sensor and water is correctly flowing. Also, you must be very careful to make sure that there will always be enough water in the water bath for the entire duration of the process.

The water pump must not run dry! This is especially relevant if the machine is not connected to a water source and you refill the water bath manually. If the error is skipped the machine will assume that there is an issue with the flow sensor, this will also prevent it from correctly suspend the temperature control process if/when it runs out of water. Pay attention!

Once started, you can skip the heating phase at your own risk, the heating will continue even during processing but the whole process will start a temperature lower than the target one.

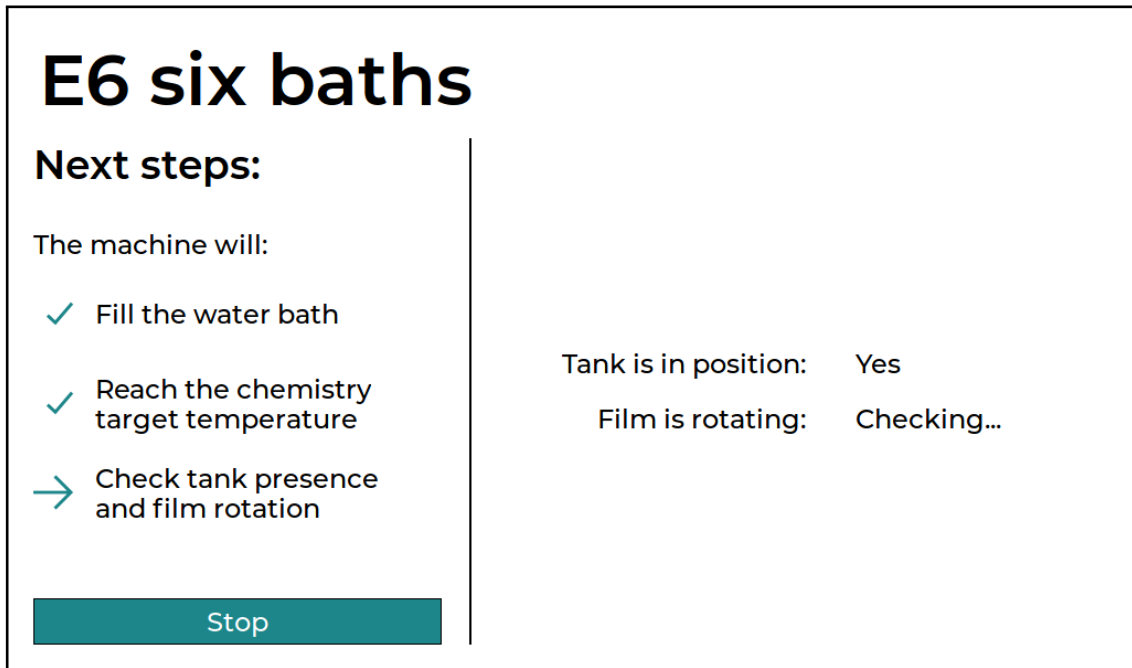

Figure 4.14: The “Tanks checks” view

Tank checks

Once the water bath is filled and heated and the chemistry has reached the correct temperature the user interface moves to the “Tank checks” view, shown in Figure 4.14. The last thing to check before starting with the actual processing is to verify that:

- the tank is in position
- the film inside the tank is rotating correctly

The window on the left side of the machine allows you to visually inspect the rotation. It must be a smooth and continuous movement, otherwise it means that something is interfering with the rotation inside the tank.

In case of errors you will be notified, the machine will produce a sound and a dialog will appear asking you to choose what to do. At this point you will be able to retry the check or to ignore the problem (at your own risk). The machine will always allow you to skip checks, especially because, apart from the previously described “water not flowing” error, the problems you may encounter will not cause any damage to the machine itself but only the film that you are about to process.

Processing

After all the preliminary checks are completed the interface will move the actual processing view, shown in Figure 4.15.

On the left you will see information about the current and following steps:

- “Step source”: the source of the current step is displayed
- “Temp. control”: the current state of the temperature control process. Its value can be “Off”, “Running” or “Suspended”.
- “Water temp.”: the current temperature measured by the sensor placed in the water bath.

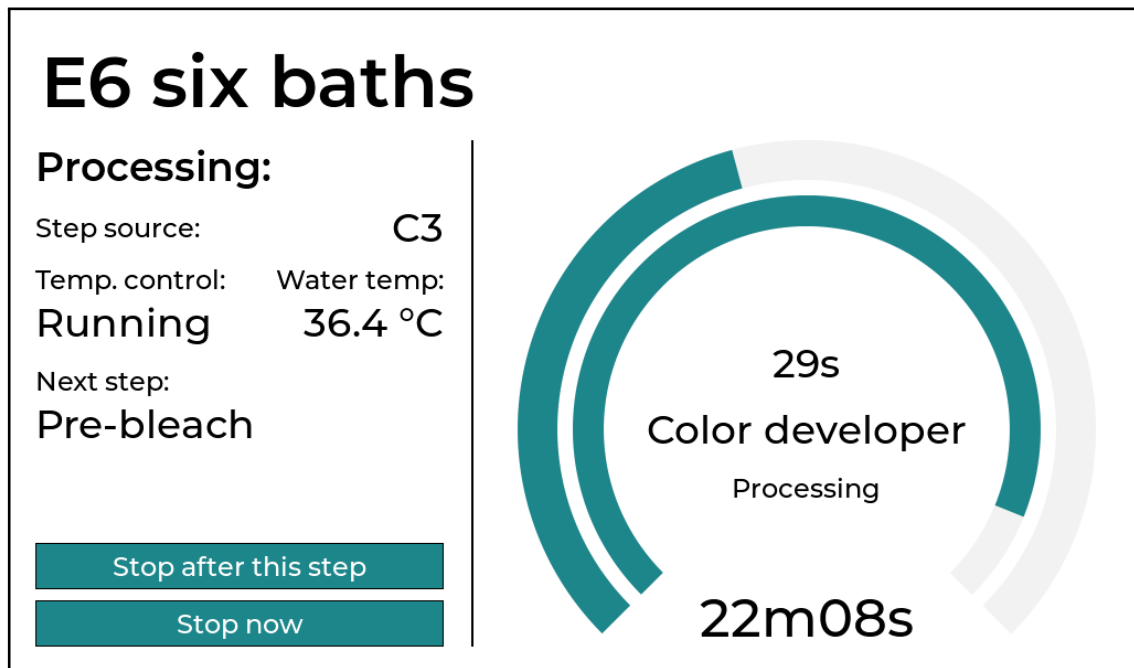

Figure 4.15: The “Processing” view

- “Next step”: the name of the next step that will be executed. If the current step is the last one, a dash will be displayed instead.

If temperature control is not active the “Temp. control” and “Water temp.” labels will be grayed out. If the temperature control process gets suspended because the water level is too low (see subsection 4.5.2 for more information about it) the “Temp. control” label will be highlighted in red to remind the user to refill the water bath.

On the right you will see two progress arcs, the outer one displays the overall progress of the process, the inner one displays the progress of the current step. You will also see two countdowns, the big one at the bottom shows the time left until the end of the process while the smaller one in the center of the arcs shows the time left until the end of the current step. Inside the arcs you can also see the name of the current step and the current operation (filling, draining or processing).

Once the processing has started, the machine (for obvious reasons) cannot be interrupted, the only thing that the user can do is to stop the process. For this purpose, on the bottom left there are two different stop buttons:

- The “Stop after this step” button will wait until the end of the current step and then will stop the process.
- The “Stop now” button will immediately stop the process.

When one of the two “Stop” buttons is clicked, a dialog warning the user about the consequences of interrupting a process will be displayed (shown in Figure 4.16). In case the “Stop now” button is pressed, the dialog also contains a switch (active by default) that can be used to immediately drain the tank before stopping the process. Draining the tank should be considered the “right” way of doing this.

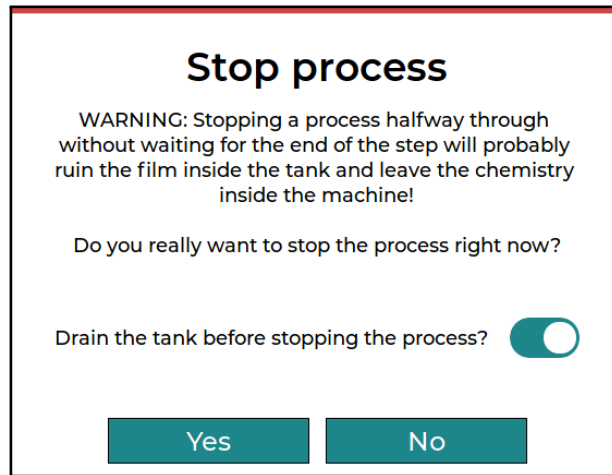

Figure 4.16: The “Stop process” dialog

**WARNING!**

Be extremely careful if you stop the process using the “Stop now” button without draining the tank first. The machine will stop processing immediately and everything will stay as is. You might end up with chemistry split between the tank and the container, or completely inside the tank. Consider this button as an “emergency stop” that can be used if something is going completely wrong with the machine and you absolutely need to stop it.

At the end of the process, the machine will play a sound and will show a dialog telling you that the process is over. Once the dialog has been closed the interface will go back to the process details. At this point, processing is over and you can unlock the tank and remove it from the machine.

4.7 Executing a process

Assuming you have already created the process, executing it is very simple. Make sure to follow these steps:

1. Make sure that all chemistry recovery faucets and the drain faucet are completely closed. The faucets are directly connected to the corresponding container and if they are not completely closed you will find yourself with some lost chemistry some cleaning to do. The drain faucet is connected to the water recirculation circuit, if left open it will allow the water to escape the circuit.
2. Place the container lids on the corresponding containers to protect the containers from splashes or spills.
3. One at a time, depending on how the process is configured, pour the chemistry in the correct containers by temporarily removing the lid. Doing this one at a time prevents splashes of chemistry to fall into the adjacent containers (you obviously don't want some of your stop bath to fall into the developer tank by accident).
4. After pouring the chemistry close the containers again with the lid. Make sure that the knob/relief valve is open by unscrewing the knob. The lids

will also help with thermal insulation during the heating phase. **This is very important since opening the relief valve will allow air to enter the container during processing. Not doing so may prevent the pumps to work correctly and result in development issues caused by less than required chemistry reaching the film tank.**

5. Make sure the tank and all its components are completely dry before loading it with film.
6. Load the film inside the tank and close it by screwing on the tank lid. Make sure to tighten the tank lid firmly. See section 2.5 for more details about this.
7. Place the tank in the correct position inside the machine by aligning the bottom lid of the tank with the plastic guides on the side of the water bath and by aligning the tank port with the connector on the bottom of the water bath. There is only one way to correctly place the tank in the machine, you will notice if something is wrong. Once you have aligned everything make sure to completely push the tank down. If your machine is equipped with mechanical rotation drive the two gears will engage when the tank is fully pushed down.
8. Lock the tank in place using the lock bar. Lower the lock bar while pulling back the spring-loaded latch mechanism, when the lock bar is completely lowered release the latch, at this point the latch should prevent the lock bar from opening. **This is very important since the lock bar, as well as preventing the tank from moving, also opens the tank relief valve. Similarly to the knobs on the chemistry container lids, starting a process with the tank relief valve closed will limit the pump ability to fill the tank up to the correct level.**
9. Select the process you want to execute using the user interface on the touch display, click on the “Play” button and follow the on-screen instructions.

If your process requires temperature control the chemistry will take some time to heat up, in this case the tank can be placed and locked into the machine later, while the chemistry is heating up. Don't worry, if you forget to place the tank in the machine and the chemistry reaches the desired temperature, the machine will warn you that the tank has not been detected and will not start the process.



Part Three: Maintenance

5	Other features	61
5.1	Internal washes	
5.2	No-lights mode	
6	Maintenance and special processes	63
6.1	Special processes	
6.2	Cleaning the machine and the “Cleaning process”	
6.3	Draining the water bath	
6.4	The “Self-check process”	
6.5	Tank presence and rotation sensors adjustment	
7	Software and data	75
7.1	Software upgrades	
7.2	User data import/export	
8	Troubleshooting	77
8.1	Common issues	

5. Other features

The machine sports some other additional features.

5.1 Internal washes

The machine always tries to wash its internals after each chemistry step by letting some clean water flow through. If the process uses the water bath, either because it requires temperature control or because one of its rinse steps have the water bath as source, the water used for internal washes can be taken from there. If the process doesn't use the water bath the machine will try to take the water from container 6. If container 6 is used in the process steps for other purposes the machine will not try to do these internal washes.

For example, if you want to execute a classic black and white process (develop, stop and fix) that doesn't require temperature control, you can use containers 1, 2 and 3 for chemistry and fill container 6 with water, the machine will use it for internal washes.

Internal washes are always enabled and are automatically managed by the machine, you don't need to manually enable them or add them to process steps.



NOTE

In cases where water is taken from container 6, the machine has no way of knowing if the container is actually filled with water so it will try to take water from it anyway, even if it's empty.

5.2 No-lights mode

Using the switch on the control panel it is possible to turn the display backlight and the power LED off in order to stop the machine from emitting light. This

feature can be extremely useful if you need complete darkness in the room while the machine is working. For example, if you have placed the machine in your darkroom, you can do other light sensitive work (like printing or loading film in other tanks) while the machine is processing some film for you.

In the “up” position the switch turns on the display backlight while in the “down” position turns them off.

**NOTE**

Be careful because only the display backlight will be turned off, not the whole display, so the touch panel input signal will still be processed!

6. Maintenance and special processes

6.1 Special processes

The machine also has three special built-in processes that are not related to film development:

- **Cleaning process:** used to automatically clean the machine and remove any chemical residues left after processing. See section 6.2 for more information.
- **Drain process:** used to drain the water bath after processing. See section 6.3 for more information about this.
- **Self-check process:** this special process is designed to guide you through a list of tasks that will test every sensor and actuator in the machine. More on this in section 6.4.

You can run them directly from the “Tools” tab in the main user interface.

6.2 Cleaning the machine and the “Cleaning process”

Chemical spills should be cleaned immediately to avoid stains, corrosion or contamination. The outside of the machine can be cleaned by wiping it using a damp cloth.

To thoroughly clean the machine and its internals there is an automatic cleaning process. This process should be run at the end of a processing session or between two different processes. We suggest running the cleaning process twice if you want to make sure that no chemistry residues will be left in the machine or if you know you that the machine won't be used for a while.

The cleaning process is customizable, that is you can choose which containers will be cleaned, how many times the process will be repeated and if the water bath must be drained at the end. After clicking on the cleaning process play button in the “Tools” tab you will be presented with a dialog that will let you customize the cleaning process, see Figure 6.1.

Figure 6.1: The cleaning process setup dialog

**WARNING!**

Before running the cleaning process make sure that:

- Chemistry has been completely removed from the selected containers (some residues are fine, they will be removed by the cleaning process).
- The faucets are all completely closed.
- Container lids have been removed from the selected containers.
- The film tank has been removed.

The cleaning process rinses all the selected containers by filling them with clean water from the bath which is then discarded, this is why the chemistry *has* to be removed, otherwise everything will overflow into the water bath, rendering the cleaning process useless.

After cleaning the containers, depending on the configuration, the water bath can be drained or not. The default cleaning configuration is that of a single cleaning process, all containers are cleaned once and what is left of the water bath is drained at the end.

When the cleaning process is done, to thoroughly clean the tubes between the chemistry containers and the faucets, open the faucets and manually let some clean water run through the containers and out of the faucets (about 300ml of water per container should be enough). After that close the faucets again.

Having a customizable cleaning process allows you to clean exactly what you need and nothing more. For example, between two runs of the same process, let's say C41 or E6, to reduce the risk of cross contamination to a minimum you can:

1. temporarily recover the developers from the containers in external bottles
2. clean only the developers containers
3. put the developers back in the corresponding containers

This way the water bath is still almost full and close to the target temperature, the developers containers have been thoroughly cleaned and the developers solutions are still near the target temperature and a new run of the same pro-

cess can begin immediately after. On the other hand, a complete cleaning process can be run when the processing session is over for the day and the machine will not be used again afterward.

The containers lids should be cleaned separately in a sink. Tanks used for processing can be cleaned like any other film development tank, rinse them thoroughly with water and wipe them with a cloth until they are completely dry. The gasket in the tank lid can be easily removed in order to better clean the tank lid and the gasket itself, wash them under running water.

Before re-using a tank to execute another process, make sure that all its components are completely dry, drops of water that end up on the film before processing may leave marks on your images.

After the cleaning process some water may be left inside the machine. Small amounts of water left in the water bath will not create a problem but full water baths should not be left in the machine for long periods of time, we suggest to completely drain the water bath after each processing session. After draining the machine, we also suggest wiping the inside of the water bath with a cloth to prevent build-up of residues over time. Chemistry containers can be cleaned using a damp cloth as well but you have to be extra careful to avoid damaging the temperature sensors inside them.

6.2.1 Removing limescale deposits

Depending on the quality of your tap water some limescale might build up in the machine over time, especially in the areas that are hard to reach with a cloth (e.g. under the chemistry containers). To remove such residues it is possible to use regular coffee machine de-scaler.

It's possible to run a cleaning process and pour about 1L of coffee machine de-scaler in the water bath before starting the process. It is possible to repeat the process one or more times depending on your needs, in this specific case you could redirect the waste output to a tank to recover the diluted de-scaler solution and reuse it in the following cleaning process runs.

After this procedure you should also run a regular water-only cleaning process again before running any other photographic development process. This is required to avoid contaminating the chemistry with diluted de-scaler solution residues that might be left inside the tubes of the machine.

6.2.2 Cleaning filters

We have added mesh filters in the inlets of the machine to avoid the risk of having small debris getting into the valves and clogging them. The risk is that something gets into a valve and prevents it from closing completely. This, in turn might easily lead to leaks, reduced pump capacity and cross-contamination issues.

In particular, the inlets that have a filter are:

- The inlets of the chemistry containers
- The tank port
- The water bath inlet
- The water recirculation inlet

It is very important to inspect them and keep the filters clean. While they prevent valves from clogging they can themselves get clogged as well and restrict the flow of water and chemistry. To clean them you can gently scrape anything

that is stuck on the mesh using a pair of tweezers or a similar tool and then remove the residues with a damp cloth.

6.3 Draining the water bath

First of all, if you find yourself with a full water bath at the end of a processing session, consider the possibility of using the water to run the cleaning process instead of draining it. After all, the machine must be cleaned after processing so it makes sense to not waste the water you already have in the water bath and use it for cleaning. If, for some other reasons, you decide to drain the water bath, you have two options:

1. Use the built-in **Draining process**: This process can be run as many times as you like depending on the situation, when you notice that there is no more water left in the machine the process can be stopped even if it hasn't reached the end (the machine has no way of knowing how much water is still left in the water bath, so it always runs for a fixed amount of time).
2. Drain the water manually using the faucet on the front marked as "Drain": this tap is directly connected to the recirculation ports on the left of the machine and it won't be possible to completely drain the bath. This happens because the recirculation ports are not the lowest point in the water bath. This method for draining the water bath is slower and doesn't completely drain it, we suggest to resort to this option only if you really need to, for example if something is malfunctioning and it's not possible to use the built-in draining process.

6.4 The "Self-check process"

The self-check process is a special process designed to guide you a list of tasks that will test every sensor and actuator in the machine. It's designed to help you diagnose potential issues with the machine.

Unlike regular processes, it's very important to actively monitor the self-check process to notice potential issues or strange behaviors. The process itself is also designed to be very interactive.

6.4.1 Before starting

After clicking on the corresponding "Play" button in the "Tools" tab of the main interface you will be presented with the screen shown in Figure 6.2.

On the left you will see the list of tasks the machine will perform while on the right, the instructions and the current status of the task will be displayed. As the instructions will tell you, a tank must be placed into the machine (with the inner column in place inside the tank), it's necessary to correctly execute the tasks.

When you have inserted the tank into the machine you can actually start the self-check process by clicking on the "Start" button. If you want to go back you can click on the "Back" button in the bottom left.

It's always possible to skip a task by clicking on the "Advance" button, just remember that you may leave the machine in an unexpected state and that the results of following tasks might be affected. You can also stop the whole

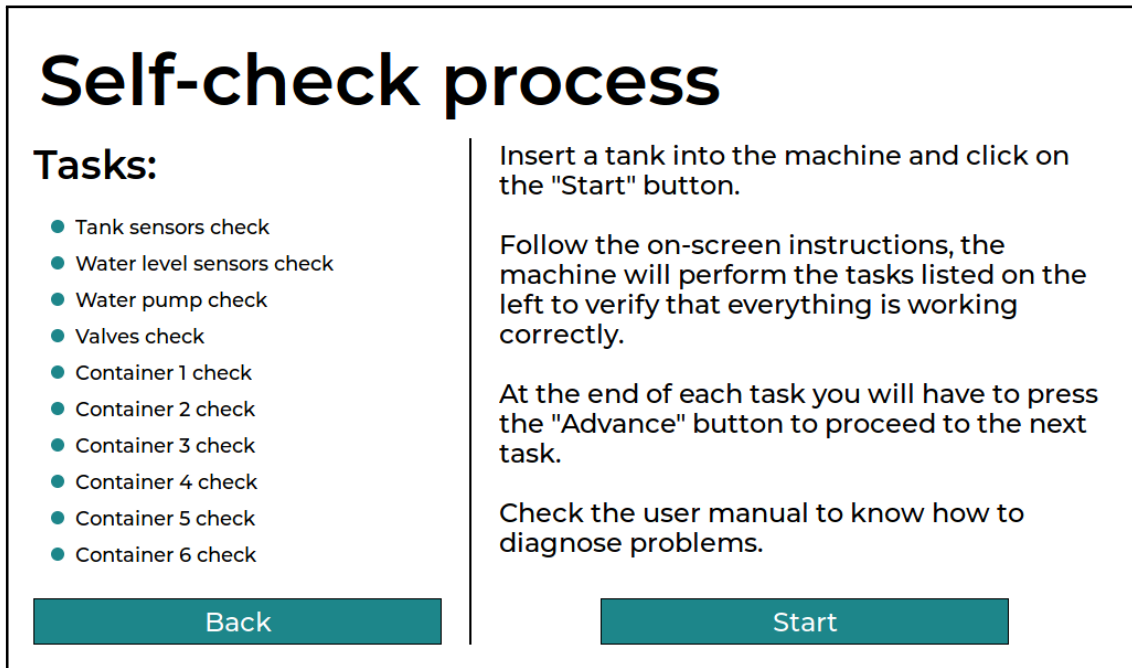

Figure 6.2: The “Ready to start” screen of the self-check process.

self-check process by clicking on the “Stop” in the bottom left, just remember that the machine will immediately stop leaving everything as is.



WARNING!

No “errors” will be reported during this process! The machine is not able to self-diagnose problems but you will be able to discover issues by observing its behavior.

Follow the on-screen instructions and carefully read this chapter!

6.4.2 The self-check tasks

Tank sensors checks

After clicking on the “Start” button the first task involves the tank sensors (see Figure 6.3).

The purpose of this task is to check if tank sensors and rotation are working as expected. At the beginning of the task the machine will start the motor, on the screen you will see the status of the presence sensor and the status of film rotation detection.

The machine will run the motor for 30 seconds then it will stop.

If your machine and tanks are equipped with mechanical rotation gears, rotation detection will always display “Yes” because in that case there is no rotation detection sensor.

If you’re having trouble with the sensors, make sure that the tank is correctly placed into the machine and that the column can freely rotate inside it. If you keep seeing “No” next to the sensors names you can try to re-adjust the two sensors, see section 6.5 for how to do this.

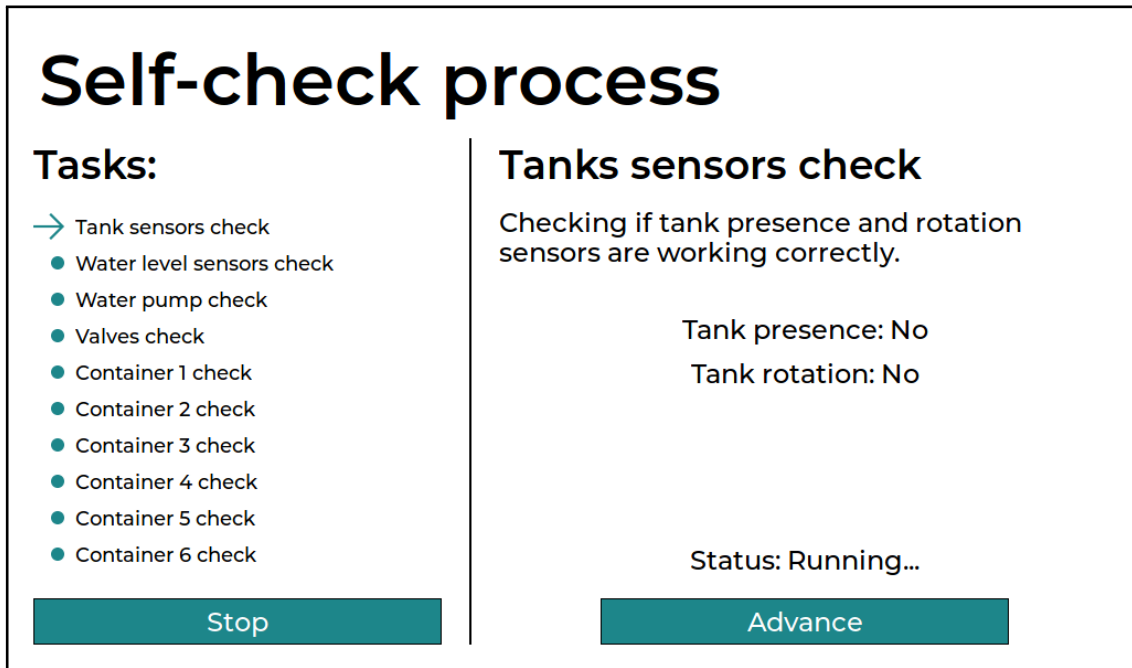

Figure 6.3: The tank sensors task screen.

Water level sensors check

After the tank sensors check the following task is the water level sensors check (see Figure 6.4).

During this task the machine will fill the water bath to check if both water level sensors are working correctly. If the water inlet on the back of the machine is connected the water bath will fill by itself, if the water inlet is not connected you will have to fill it manually.

You can monitor the status of the water level sensors in the middle of the screen.

Water pump check

After the water level sensors check the following task will check the water pump and flow sensor, (see Figure 6.5).

During this task the machine will try to start the water pump to verify if both the pump itself and the flow sensor are working correctly.

If the flow sensor doesn't immediately detect flow the pump will stop after 3 seconds to avoid running dry, it will then retry after another 3 seconds. If after 20 tries the flow sensor still doesn't detect any flow, it will give up. When the flow sensor detects flow, the pump will keep running for another 20 seconds and finally mark the task as completed.

If the pump is not able to start it's almost definitely because of air trapped into its circuit, you can "help" the pump by manually filling the circuit with a syringe, as explained in section 4.6.6.

If you can see that the pump is running correctly (water is flowing out from the recirculation port on the right under container 6) but it keeps stopping and restarting because the flow sensor is not detecting anything then, there might be an issue with the sensor itself.

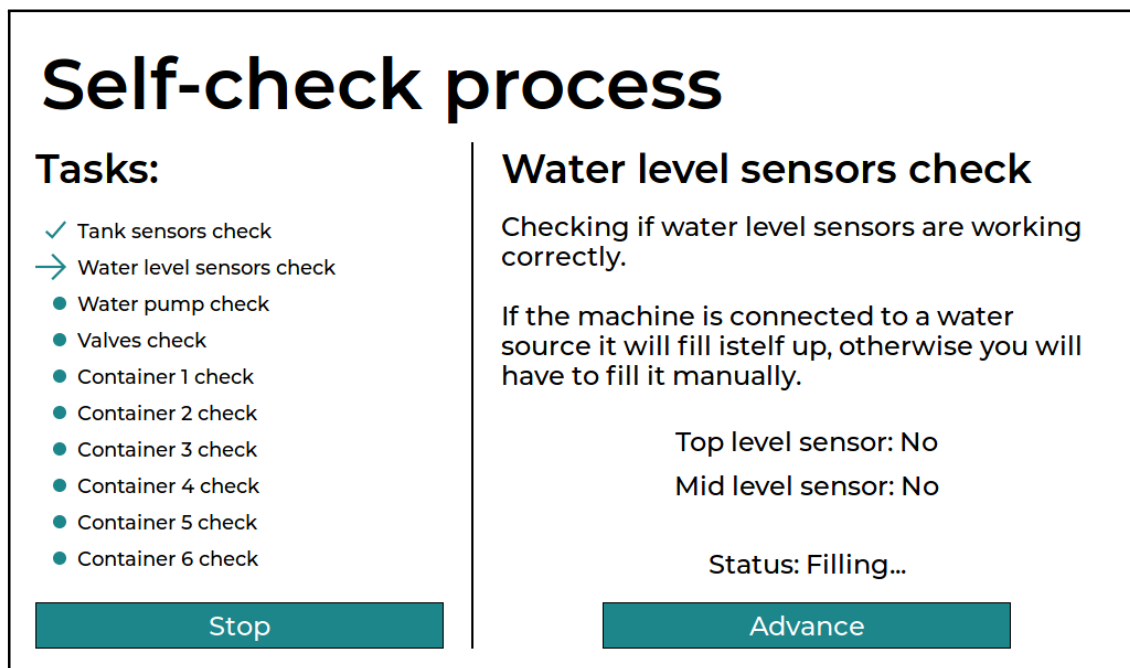

Figure 6.4: The water level sensors task screen.

Valves check

After checking the water pump and the flow sensor it's time to check all the valves, (see Figure 6.6).

Our machine contains various valves that open and close during processing to direct the flow of chemistry and water to the right places. If the machine is not used for a long period of time (more than one month) the membrane in some valves may get stuck. This problem can usually be fixed by simply opening and closing the valves repeatedly.

This task will simply try to open and close each valve repeatedly, a valve that is working correctly will produce a distinctive “clunk” sound every time it is operated while a valve that is stuck will remain silent.

You will see two progress bars above the “Advance” button, the bottom one displays the progress of the whole valve check task while the top one displays the progress for each valve.

Containers checks

The last series of tasks is used to check pumping operations for each chemistry container (see Figure 6.7)

This series of task verifies that the chemistry pumps are working correctly for each container. For each container the machine will:

- Move about 500ml of water from the water bath to the tank.
- Move the same water from the tank into chemistry container that is currently tested.
- Drain the container and discard the water through the waste outlet.

You will see two progress bars above the “Advance” button, the bottom one displays the progress of the whole container check task currently being executed while the top one displays the progress of the current sub-phase of the task (filling the tank, filling the container or draining the container).

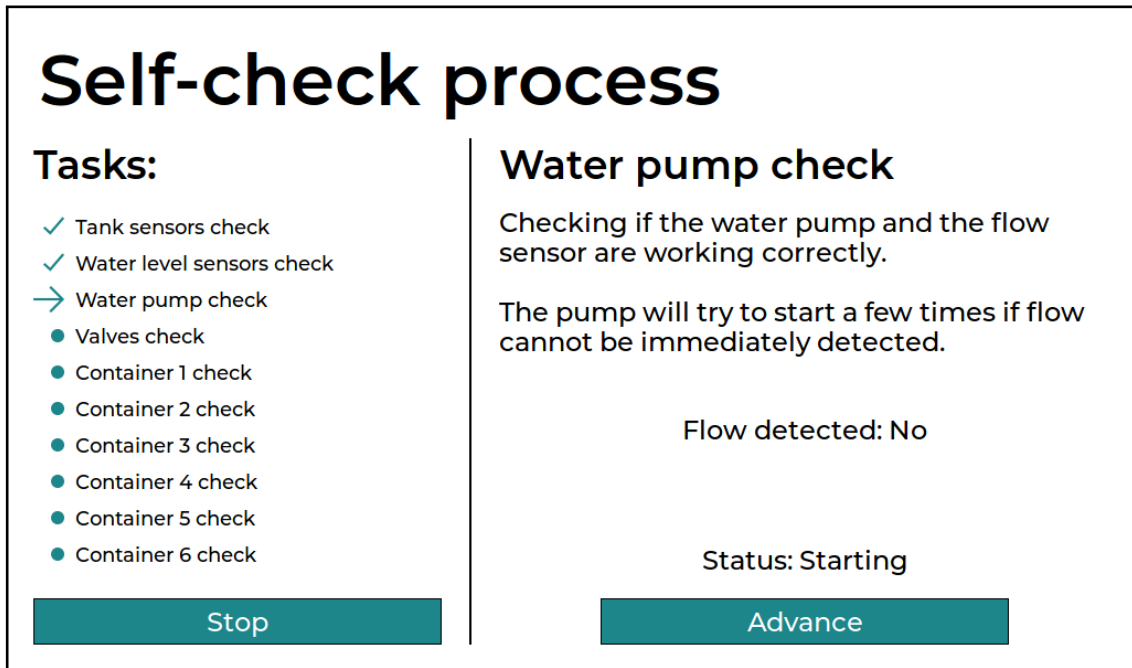

Figure 6.5: The water pump and flow sensor check task screen.

You should see the same amount of water coming up into each container. An issue with one of the container could be seeing some water coming up into it when it shouldn't (a valve that it's not properly closed) or less water than expected coming up into it (a valve that is not fully open).

After checking pumping in all containers the process is finished and you can go back to the "Tools" tab of the main screen.

6.5 Tank presence and rotation sensors adjustment



NOTE

This section applies only to those machines equipped with magnetic rotation. The ones equipped with mechanical gears rotation don't have a rotation sensor and have a completely different motor assembly.

The machine obviously comes with pre-adjusted presence and rotation sensors. Sometimes though, if you notice that you are getting too many false-positive rotation errors, it may be because of a misaligned rotation detection sensor.

Inside the base of the tank inner column, there is a ring of embedded magnets that get coupled with an identical ring of magnets mounted on the motor and drive the rotation movement.

Rotation is monitored using another magnet, embedded into the inner column base as well. This magnet, when the inner column rotates, passes in front of a magnetic sensor. The position of this sensor is very important and it's possible to adjust it if necessary.

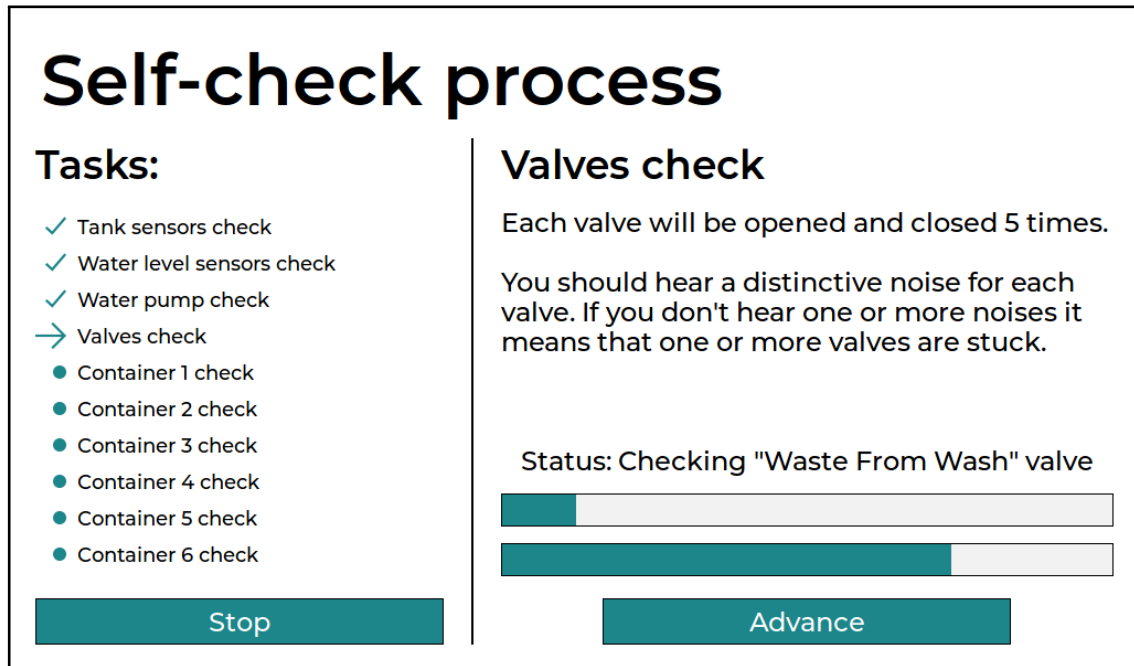

Figure 6.6: The valves check task screen.

To adjust the rotation sensor is necessary to first remove the left side panel. Unscrew the 8 torx screws along its edges and put it aside.

You will see two magnetic sensors (blue plastic and gray cable, number 7 in Figure 6.8) mounted on the bottom of the motor assembly. The sensor on the left is the presence sensor and it's fixed in place, the sensor on the right is the rotation sensor.

To help in this task there are two small LEDs on the breakout board at the top of the motor assembly. One of them represents the status of the presence sensor (it should be on when the tank is placed into the machine), the other one represents the status of the rotation sensor (it turns on when the magnet embedded in the base of the inner column passes in front of the sensor).

These two LEDs are not enabled by default, just like all the other ones on the board to prevent any light escaping from the inside of the machine. To enable them you have to use the toggle switch below the motor assembly, next to a DB9 connector and an Ethernet port.

Follow these steps to adjust the position of the rotation sensor:

1. Enable the LEDs using the toggle switch.
2. Place a closed tank with the inner column fitted into the machine. You should see one of the LEDs turning steadily on when you insert the tank, this means that the presence sensor is working correctly.
3. Loosen the self-locking nut that holds the rotation sensor in place (number 8 in Figure 6.8) so that the sensor is free to move around.
4. Start the self-check process and move to the tank sensors task. When the motor start spinning try to move the rotation sensor in a place where it picks up the magnets in the base once per rotation (e.g. if rotation speed is 60 rpm you should see the LED turning one once every second). The correct position should be somewhere in the middle of the available positioning range.

Self-check process

Tasks:

- ✓ Tank sensors check
- ✓ Water level sensors check
- ✓ Water pump check
- ✓ Valves check
- ✓ Container 1 check
- ✓ Container 2 check
- Container 3 check
- Container 4 check
- Container 5 check
- Container 6 check

Stop

Container 3 check

Checking pump operations on C3.

The machine will:

- Fill the tank from the water bath
- Fill C3 from the tank with 500 ml
- Discard the water

Status: Draining container

Advance

Figure 6.7: The containers check task screen.

5. Once the correct position is found, tighten the self-locking nut (number 8). Be careful when you tighten it because it might move a bit.
6. When you're done remember to turn off the LEDs using the toggle switch before re-mounting the side panel!

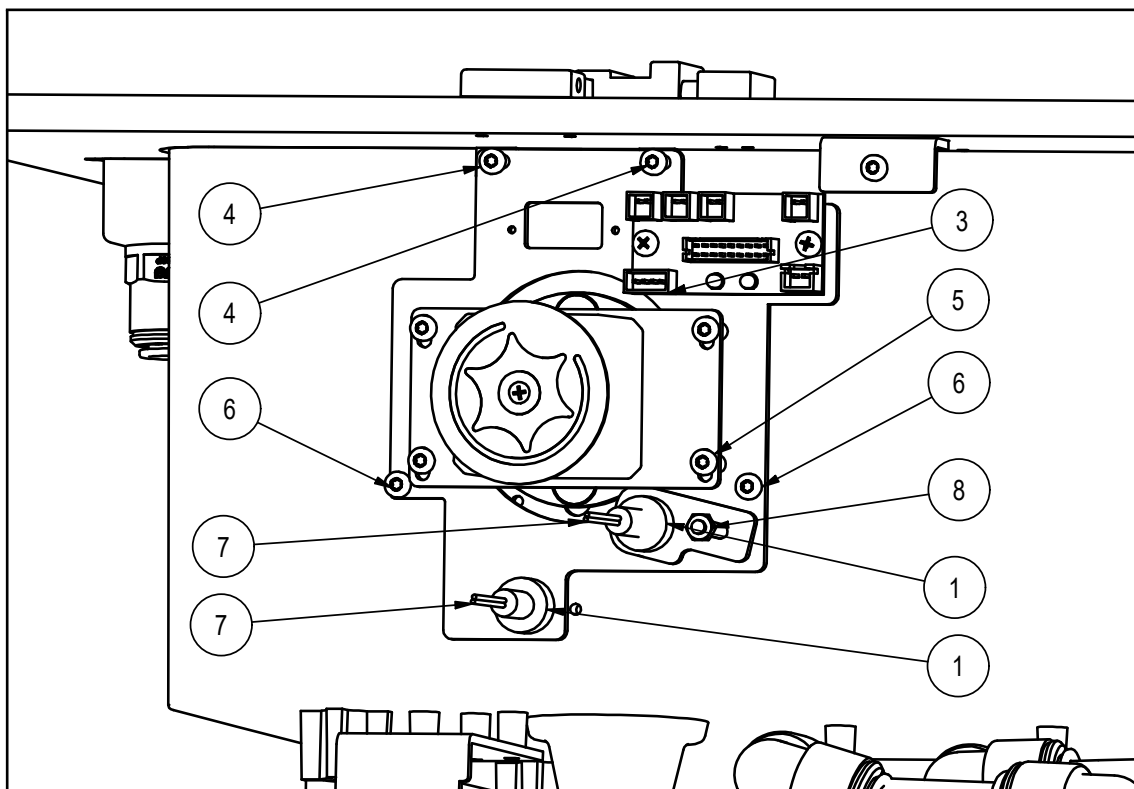

Figure 6.8: The motor assembly and its components.

7. Software and data

The following sections involve the use of a USB drive to transfer data to or from the machine, whether it's for upgrades or processes and settings operations. The USB drive in question must be formatted using the following file systems:

- NTFS (used by Windows)
- FAT32 (compatible with Windows, macOS and Linux)
- HFS+ (used by Mac OS X)
- Ext4 (used by Linux)

7.1 Software upgrades

Software upgrades are provided as “upgrade packages”, these packages are files with the “.afdu” extension that can be downloaded from our website. To perform an upgrade to a more recent version of the software follow these steps:

- Copy the upgrade package file that you want to install on a USB drive.
- Insert the drive in the USB port under the display.
- In the interface go to the “Tools” tab in the main view and, under the “Software” section, click on the “Upgrade” button.
- The upgrade dialog will appear, when you are ready click on the “Start” button to begin with the upgrade procedure. The progress bar shows the status of the upgrade. Once started, the upgrade procedure is completely automatic and cannot be stopped.
- When the upgrade is over you will see a message with the outcome of the operation.

After a successful upgrade you will have to reboot the machine to make it effective. After a successful upgrade the “Start” button will change into the “Reboot” button, you can click it and the machine will automatically reboot without needing a power cycle. A failed upgrade does not compromise the machine in any way, you can continue to use it just as before.

**NOTE**

It's technically possible to downgrade the software and install an older version **but we don't recommend it**. Software upgrades always contain new features and bug fixes that will improve your experience with our machine. Also, in some cases, some user data stored on the machine might get lost if an older version that is not able to support it is installed.

Older software versions are not freely available and if you really think that you need to downgrade the software on your machine, please contact us first.

7.2 User data import/export

It is possible to import or export the configuration and the processes stored on the machine to and from a USB drive. This functionality can be useful for backup purposes or to transfer the configuration of a machine to another one. The machine uses a proprietary file format with the ".afdd" extension.

7.2.1 Exporting data

To export configuration and processes follow these steps:

- Insert a USB drive into the USB port under the display.
- In the interface go to the "Tools" tab in the main view and, under the "Utilities" section, click on the "Play" icon of the "Export" green box.
- A dialog will appear on the screen, when you are ready click on the "Export" button.
- A message will appear reporting if the machine was able to export the data or not.
- Remove the USB drive, it should now contain a file named "FilmDeveloperUserData.afdd"

7.2.2 Importing data

To import configuration and processes follow these steps:

- Insert a USB drive into the USB port under the display. The drive should contain a file with the ".afdd" extension, if more than one file ends with the ".afdd" extension then the first in lexicographical order is selected.
- In the interface go to the "Tools" tab in the main view and, under the "Utilities" section, click on the "Play" icon of the "Import" green box.
- A dialog will appear on the screen, when you are ready click on the "Import" button.
- A message will appear reporting if the machine was able to import the data or not.
- Remove the USB drive.

**WARNING!**

Be careful with the import function! By importing processes and configuration from a USB drive you will completely overwrite the current configuration of the machine and the operation cannot be undone.

8. Troubleshooting

This is a quite complex machine and there are almost no user serviceable parts.

To avoid any risk of damage or electrical shock, **do not** open the machine and **do not** attempt to fix it on your own, opening the machine will also void your warranty! If you are having issues and you are not sure on how to proceed, please don't hesitate to contact us at support@analogico.adel2000.it or to contact your local distributor.

8.1 Common issues

Here is a list of common issues that you might face while using our machine.

Issue: The machine doesn't turn on.

Action: If the machine doesn't turn on there are a couple of things to check:

- Verify if the switch next to the display is in the "ON" position. When the switch is in the "OFF" position the machine shows no signs of life even if it's turned on. Move the switch to the "ON" position and check again. If the display back-light is turned off it may seem as if the machine is not turning on.
- Check if the power cord is not damaged and it is correctly connected to both the mains and the socket on the back of the machine. If the power cord gets damaged you must replace it with another one of the same type.
- With the power switched off, check if the fuses in the machine socket are not blown. If they are blown you can try to replace them and check again (make sure to use the correct ones). If the problem persists you should contact us for support. If you live in the UK or in a country that uses the same plugs remember to check the fuse in the plug as well.

Issue: The water inlet on the back of the machine marked as "WATER IN" is correctly plumbed in but the machine keeps displaying a message telling

that the machine is not connected to a water source.

Action: The machine doesn't have a sensor to detect if the inlet on the back is connected to a water source or not so it must be told explicitly in the configuration. See subsection 4.6.2 for more information about this and a description of the configuration options.

Issue: Less chemistry than expected is transferred from the chemistry containers to the tank.

Action: If you expect the machine to move a certain amount of chemistry into the tank but you notice that, for example, only about half of it is actually transferred it might be because of one or more of the following reasons:

- The wrong tank size or the wrong chemistry amount have been chosen by mistake before starting the process.
- One or more knobs on top of the chemistry containers are closed, effectively sealing the container. They must be open during processing to let air in and out of the container.
- The tank relief valve was not correctly open during processing. It must be opened by the tank lock bar pin to let air in and out of the tank during processing.
- If all the above can be excluded the chemistry pumps might not work correctly. In this case you need to contact your local distributor for support.

Issue: False-positive rotation errors are detected when pumps are running.

Action: Update to the latest software version. Earlier versions (before v1.1.4.54) were not handling electrical noise coming from the pump correctly, effectively displaying rotation false rotation errors.

Issue: Rotation errors are still frequently detected, even after upgrading to the latest software version.

Action: If you're hearing scratching-like noises coming from the tank during film rotation it means that something inside the tank is not loaded correctly. If the process is still in the early checking phase stop it and check if everything in the tank is in order. If the process is already running make sure to check if everything is alright before the next processing run.

Also make sure to correctly mount the film clips, this will prevent the film from coming off the reels during processing or to extend outside the outer edge of the reel and, possibly, coming in contact with the tank walls or with other elements.

If you keep getting rotation errors it might be necessary to readjust the position of the rotation detection sensor, in this case get in touch with your local distributor for guidance in solving this issue.

Issue: After executing a second consecutive run of the same process negatives appear much thinner and not developed correctly.

Action: This is most likely caused by developer cross-contamination with the fixer or the bleach (if it's a color process). If you want to execute multiple consecutive runs of the same process make sure to wash the tank and reels thoroughly between runs and to include a long multi-rinse step at the end of the process with at least 4 water changes (for example, if you have set the multi-rinse cycle

duration to 2 minutes, to have 4 water changes the duration of the multi-rinse step must be of at least 8-10 minutes).

Issue: The machine tried to execute one of the steps but the solution stayed in the chemistry container.

Action: If the machine tried to execute the step but failed, it probably is because the valve under the chemistry container didn't open. This might be because the valve is somehow stuck, in this case you should run the valve check process and verify if you can hear all valves operating correctly.

If this doesn't solve the issue, even after a few "Valve check" process executions, it might be an electrical issue, in this case it's better to contact your local distributor for support.

Issue: The machine pumps chemistry to and from more than one tank at a time.

Action: If you see more than one chemistry containers being used at the same time it probably is because one of the valves doesn't close properly and let the contents of the corresponding container through to the tubes inside the machine.

The same might be true if you see some chemistry coming out of the port on the bottom of the water bath, in this case the stuck valve is the one under the water bath.

The valve in question might be stuck because something got into the valve mechanism and prevents the valve from closing properly. In this case you can run a cleaning process one or more times, that will flush all the valves in the machine, hopefully dislodging any debris stuck in chemistry tube circuit.

If you still experience the issue it could be because of an electrical issue that makes two or more valves "working together", in this case you should contact your local distributor for support.

Issue: One or more containers are overflowing when the machine brings the chemistry back to them from the tank or a lot of water is left in the tank.

Action: This issue might have two possible sources:

- It might be a similar situation to the one described previously, in this case the valve stuck open would be the one under the water bath. If something like small debris or small pieces of plastic do not allow the valve to close completely then it will let water from the water bath flow in when the machine moves chemistry from the container to the tank.
- The tank is not correctly closed and water leaks inside it when immersed in the water bath. To rule out this possibility you check if your tank is not leaking by immersing it in water for a while and check for bubbling or water inside it.

Issue: An error message says that one or more temperature sensors are not working properly.

Action: During the startup phase the machine verifies if all the temperature sensors are working correctly. If it detects that a sensor is malfunctioning it will display an error message on the screen. While replacing a temperature sensor is not an easy task and it should be performed by us or by one of our distributors,

you can still use the machine as long as the processes that you want to execute don't need temperature readings from the broken sensors.

Issue: The user interface on the display is stuck and doesn't respond to touch input.

Action: In this case it's almost definitely a software bug and the only thing to do is to turn the machine off and on again.

If this happens during the execution of a process and you can still hear the machine correctly executing the process (valves and pumps are turning on as expected) then let it finish, even if you can't check the progress on the screen. In this case only the user interface crashed but the rest of the machine is still working normally.

If something like this happens, or any other software issue, please contact us and describe what happened in as many details as possible. We will work on fixing the software bug as quickly as possible.

**the star of all film
developing machines.**
